

## MIXED SIGNAL MICROCONTROLLER

### FEATURES

- Low Supply Voltage Range: 1.8 V to 3.6 V
- Ultralow Power Consumption
  - Active Mode (AM): 180  $\mu$ A/MHz
  - Standby Mode (LPM3 WDT Mode, 3 V): 1.1  $\mu$ A
  - Off Mode (LPM4 RAM Retention, 3 V): 0.9  $\mu$ A
  - Shutdown Mode (LPM4.5, 3 V): 0.25  $\mu$ A
- Wake-Up From Standby Mode in Less Than 5  $\mu$ s
- 16-Bit RISC Architecture, Extended Memory, 40-ns Instruction Cycle Time
- Flexible Power Management System
  - Fully Integrated LDO With Programmable Regulated Core Supply Voltage
  - Supply Voltage Supervision, Monitoring, and Brownout
- Unified Clock System
  - FLL Control Loop for Frequency Stabilization
  - Low-Power/Low-Frequency Internal Clock Source (VLO)
  - Low-Frequency Trimmed Internal Reference Source (REFO)
  - 32-kHz Crystals (XT1)
  - High-Frequency Crystals up to 25 MHz (XT1)
- Hardware Multiplier Supporting 32-Bit Operations
- Three Channel DMA
- Up to Twelve 5-V Tolerant Digital Push/Pull I/Os With Up to 20-mA Drive Strength<sup>(1)</sup>
- 16-Bit Timer TD0 With Three Capture/Compare Registers and Support of High-Resolution Mode
- 16-Bit Timer TD1 With Three Capture/Compare Registers and Support of High-Resolution Mode
- 16-Bit Timer TA0 With Three Capture/Compare Registers
- Universal Serial Communication Interfaces<sup>(1)</sup>
  - USCI\_A0 Supporting
    - Enhanced UART Supporting Auto-Baudrate Detection
    - IrDA Encoder and Decoder
    - Synchronous SPI
  - USCI\_B0 Supporting
    - I<sup>2</sup>C™
    - Synchronous SPI
- 10-Bit 200-ksp/s Analog-to-Digital (A/D) Converter
  - Internal Reference
  - Sample-and-Hold
  - Autoscan Feature
  - Up to Eight External Channels, Two Internal Channels, Including Temperature Sensor<sup>(1)</sup>
- Up to 16-Channel On-Chip Comparator Including an Ultralow-Power Mode<sup>(1)</sup>
- Serial Onboard Programming, No External Programming Voltage Needed
- Family Members are Summarized in [Table 1](#)
- Available in 40-Pin QFN (RSB) and 38-Pin TSSOP (DA) Packages (See [Table 2](#))
- For Complete Module Descriptions, See the *MSP430x5xx/MSP430x6xx Family User's Guide (SLAU208)* <sup>(1)</sup>

(1) Full functionality in the 40-pin QFN package options. For the available features of other packages see [Terminal Functions](#).



Please be aware that an important notice concerning availability, standard warranty, and use in critical applications of Texas Instruments semiconductor products and disclaimers thereto appears at the end of this data sheet.

MSP430 is a trademark of Texas Instruments.

All other trademarks are the property of their respective owners.

## DESCRIPTION

The Texas Instruments MSP430™ family of ultralow-power microcontrollers consists of several devices featuring different sets of peripherals targeted for various applications. The architecture, combined with five low-power modes, is optimized to achieve extended battery life in portable measurement applications. The device features a powerful 16-bit RISC CPU, 16-bit registers, and constant generators that contribute to maximum code efficiency. The digitally controlled oscillator (DCO) allows wake up from low-power modes to active mode in less than 5 µs.

The MSP430F51x2 series are microcontroller configurations with two 16-bit high-resolution timers, universal serial communication interfaces (USCI\_A0 and USCI\_B0), 32-bit hardware multiplier, a high performance 10-bit analog-to-digital (A/D) converter, on-chip comparator, three-channel DMA, 5-V tolerant I/Os, and up to 29 I/O pins.

The MSP430F51x1 series are microcontroller configurations with two 16-bit high-resolution timers, universal serial communication interfaces (USCI\_A0 and USCI\_B0), 32-bit hardware multiplier, on-chip comparator, three-channel DMA, 5-V tolerant I/Os, and up to 29 I/O pins.

Typical applications for these devices include analog and digital sensor systems, LED lighting, digital power supply, motor control, remote controls, thermostats, digital timers, hand-held meters, etc.

Family members available are summarized in [Table 1](#).

**Table 1. Family Members**

Device	Flash (KB)	SRAM (KB)	Timer_A <sup>(1)</sup>	Timer_D <sup>(2)</sup>	USCI		ADC10_A (Ch)	Comp_B (Ch)	I/O	Package Type
					Channel A: UART/IrDA/SPI	Channel B: SPI/I <sup>2</sup> C				
MSP430F5172	32	2	3	3, 3	1	1	9 ext / 2 int	16	31	40 QFN
							8 ext / 2 int	15	29	38 TSSOP
MSP430F5152	16	2	3	3, 3	1	1	9 ext / 2 int	16	31	40 QFN
							8 ext / 2 int	15	29	38 TSSOP
MSP430F5132	8	1	3	3, 3	1	1	9 ext / 2 int	16	31	40 QFN
							8 ext / 2 int	15	29	38 TSSOP
MSP430F5171	32	2	3	3, 3	1	1	-	16	31	40 QFN
							15	29	38 TSSOP	
MSP430F5151	16	2	3	3, 3	1	1	-	16	31	40 QFN
							15	29	38 TSSOP	
MSP430F5131	8	1	3	3, 3	1	1	-	16	31	40 QFN
							15	29	38 TSSOP	

- (1) Each number in the sequence represents an instantiation of Timer\_A with its associated number of capture compare registers and PWM output generators available. For example, a number sequence of 3, 5 would represent two instantiations of Timer\_A, the first instantiation having 3 and the second instantiation having 5 capture compare registers and PWM output generators, respectively.
- (2) Each number in the sequence represents an instantiation of Timer\_D with its associated number of capture compare registers and PWM output generators available. For example, a number sequence of 3, 5 would represent two instantiations of Timer\_D, the first instantiation having 3 and the second instantiation having 5 capture compare registers and PWM output generators, respectively.

**Table 2. Ordering Information<sup>(1)</sup>**

T <sub>A</sub>	PACKAGED DEVICES <sup>(2)</sup>	
	PLASTIC 38-PIN DA (TSSOP)	PLASTIC 40-PIN RSB (QFN)
-40°C to 85°C	MSP430F5132IDA	MSP430F5132IRSB
	MSP430F5152IDA	MSP430F5152IRSB
	MSP430F5172IDA	MSP430F5172IRSB
	MSP430F5131IDA	MSP430F5131IRSB
	MSP430F5151IDA	MSP430F5151IRSB
	MSP430F5171IDA	MSP430F5171IRSB

- (1) For the most current package and ordering information, see the Package Option Addendum at the end of this document, or see the TI web site at [www.ti.com](http://www.ti.com).
- (2) Package drawings, thermal data, and symbolization are available at [www.ti.com/packaging](http://www.ti.com/packaging).

### Functional Block Diagram, MSP430F51x2

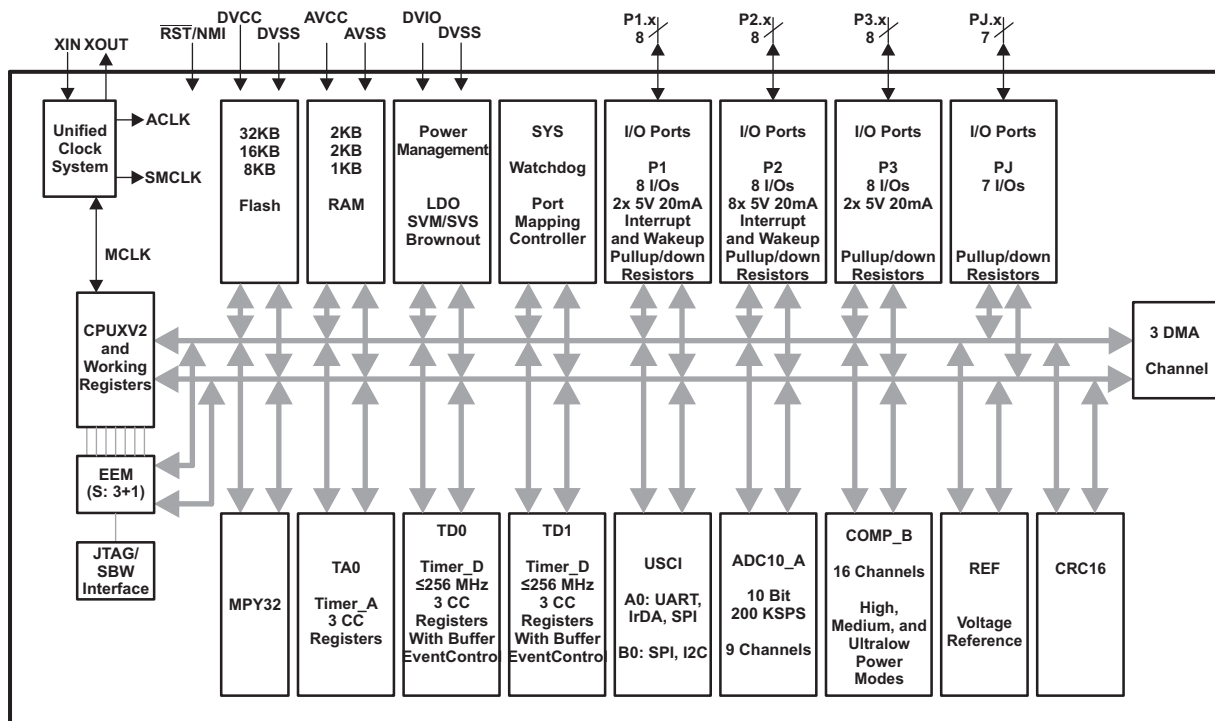

### Functional Block Diagram, MSP430F51x1

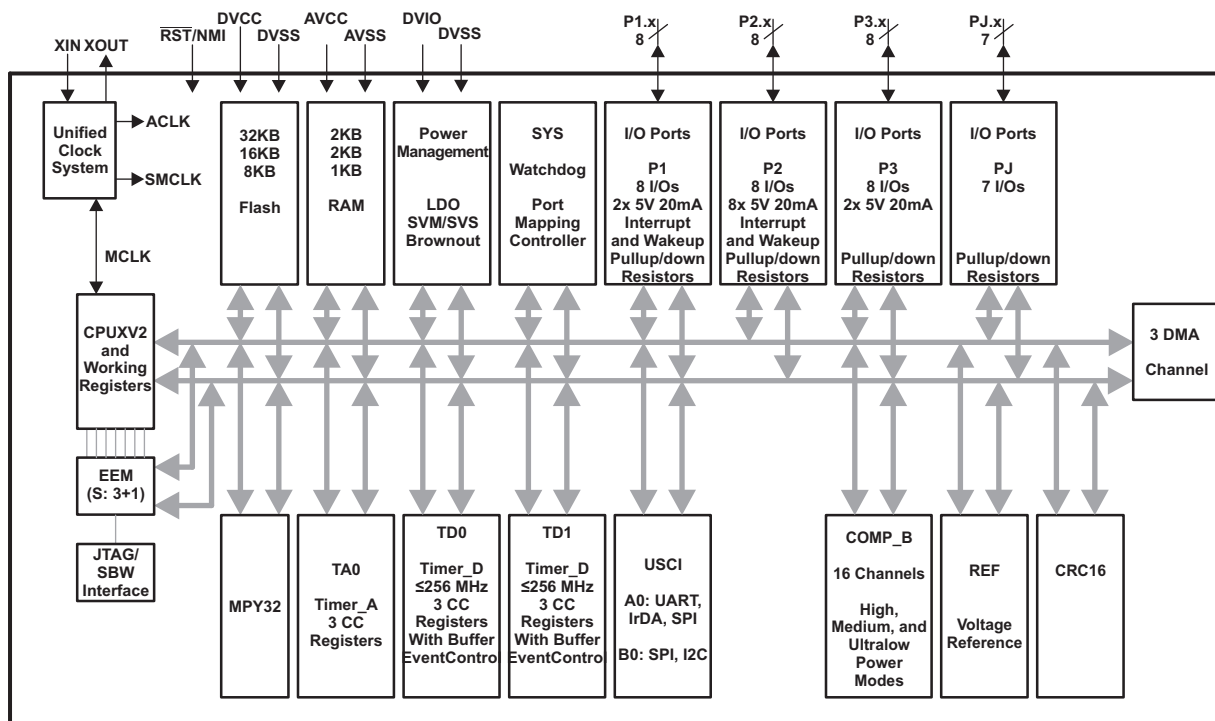

**Pin Designation, MSP430F51x2IRSB and MSP430F51x1IRSB**

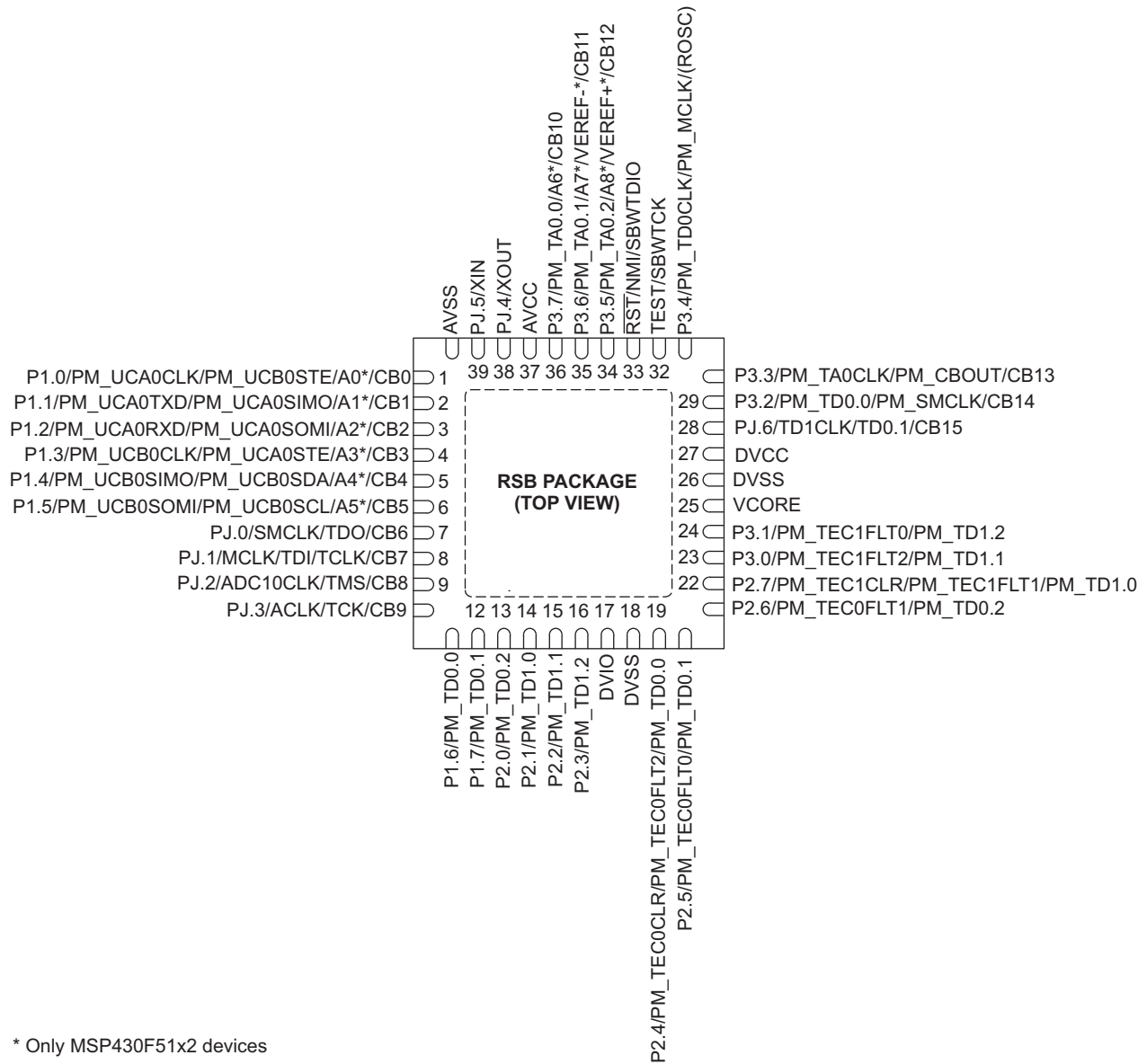

**Pin Designation, MSP430F51x2IDA and MSP430F51x1IDA**

AVCC	1	○	38	P3.6/PM_TA0.1/A7*/VEREF-*/CB11
PJ.4/XOUT	2		37	P3.5/PM_TA0.2/A8*/VEREF+*/CB12
PJ.5/XIN	3		36	RST/NMI/SBWDIO
AVSS	4		35	TEST/SBWTCK
P1.0/PM_UCA0CLK/PM_UCB0STE/A0*/CB0	5		34	P3.3/PM_TA0CLK/PM_CBOUT/CB13
P1.1/PM_UCA0TXD/PM_UCA0SIMO/A1*/CB1	6		33	P3.2/PM_TD0.0/PM_SMCLK/CB14
P1.2/PM_UCA0RXD/PM_UCA0SOMI/A2*/CB2	7		32	PJ.6/TD1CLK/TD0.1/CB15
P1.3/PM_UCB0CLK/PM_UCA0STE/A3*/CB3	8		31	DVCC
P1.4/PM_UCB0SIMO/PM_UCB0SDA/A4*/CB4	9		30	DVSS
P1.5/PM_UCB0SOMI/PM_UCB0SCL/A5*/CB5	10		29	VCORE
PJ.0/SMCLK/TDO/CB6	11		28	P3.1/PM_TEC1FLT0/PM_TD1.2
PJ.1/MCLK/TDI/TCLK/CB7	12		27	P3.0/PM_TEC1FLT2/PM_TD1.1
PJ.2/ADC10CLK/TMS/CB8	13		26	P2.7/PM_TEC1CLR/PM_TEC1FLT1/PM_TD1.0
PJ.3/ACLK/TCK/CB9	14		25	P2.6/PM_TEC0FLT1/PM_TD0.2
P1.6/PM_TD0.0	15		24	P2.5/PM_TEC0FLT0/PM_TD0.1
P1.7/PM_TD0.1	16		23	P2.4/PM_TEC0CLR/PM_TEC0FLT2/PM_TD0.0
P2.0/PM_TD0.2	17		22	DVSS
P2.1/PM_TD1.0	18		21	DVIO
P2.2/PM_TD1.1	19		20	P2.3/PM_TD1.2

**DA PACKAGE  
(TOP VIEW)**

\* Only MSP430F51x2

Terminal Functions

Table 3. Terminal Functions

TERMINAL		NO.	I/O <sup>(1)</sup>	DESCRIPTION
NAME	RSB			
P1.0/ PM_UCA0CLK/  PM_UCB0STE/ A0/ CB0 <sup>(2)</sup>	1	5	I/O	General-purpose digital I/O Clock signal input – USCI_A0 SPI slave mode Clock signal output – USCI_A0 SPI master mode Slave transmit enable – USCI_B0 SPI mode Analog input A0 – 10-bit ADC (see ) Comparator_B Input 0
P1.1/ PM_UCA0TXD/ PM_UCA0SIMO/ A1/ CB1 <sup>(2)</sup>	2	6	I/O	General-purpose digital I/O Transmit data – USCI_A0 UART mode Slave in, master out – USCI_A0 SPI mode Analog input A1 – 10-bit ADC <sup>(2)</sup> Comparator_B Input 1
P1.2/ PM_UCA0RXD/ PM_UCA0SOMI/ A2/ CB2 <sup>(2)</sup>	3	7	I/O	General-purpose digital I/O Receive data – USCI_A0 UART mode Slave out, master in – USCI_A0 SPI mode Analog input A2 – 10-bit ADC <sup>(2)</sup> Comparator_B Input 2
P1.3/ PM_UCB0CLK/  PM_UCA0STE/ A3/ CB3 <sup>(2)</sup>	4	8	I/O	General-purpose digital I/O Clock signal input – USCI_B0 SPI slave mode Clock signal output – USCI_B0 SPI master mode Slave transmit enable – USCI_A0 SPI mode Analog input A3 – 10-bit ADC <sup>(2)</sup> Comparator_B Input 3
P1.4/ PM_UCB0SIMO/ PM_UCB0SDA/ A4/ CB4 <sup>(2)</sup>	5	9	I/O	General-purpose digital I/O Slave in, master out – USCI_B0 SPI mode I2C data – USCI_B0 I2C mode Analog input A4 – 10-bit ADC <sup>(2)</sup> Comparator_B Input 4
P1.5/ PM_UCB0SOMI/ PM_UCB0SCL/ A5/ CB5 <sup>(2)</sup>	6	10	I/O	General-purpose digital I/O Slave out, master in – USCI_B0 SPI mode I2C clock – USCI_B0 I2C mode Analog input A5 – 10-bit ADC <sup>(2)</sup> Comparator_B Input 5
PJ.0/ SMCLK/ TDO/ CB6	7	11	I/O	General-purpose digital I/O SMCLK clock output Test data output port Comparator_B Input 6
PJ.1/ MCLK/ TDI/TCLK/ CB7	8	12	I/O	General-purpose digital I/O MCLK clock output Test data input or test clock input Comparator_B Input 7
PJ.2/ ADC10CLK/ TMS/ CB8	9	13	I/O	General-purpose digital I/O ADC10_A clock output Test mode select Comparator_B Input 8
PJ.3/ ACLK/ TCK/ CB9	10	14	I/O	General-purpose digital I/O ACLK output port Test clock Comparator_B Input 9
P1.6/ PM_TD0.0	11	15	I/O, DV <sub>IO</sub>	General-purpose digital I/O TD0 CCR0 compare output/capture input
P1.7/ PM_TD0.1	12	16	I/O, DV <sub>IO</sub>	General-purpose digital I/O TD0 CCR1 compare output/capture input
P2.0/ PM_TD0.2	13	17	I/O, DV <sub>IO</sub>	General-purpose digital I/O TD0 CCR2 compare output/capture input

(1) I = input, O = output, N/A = not available on this package offering  
(2) The ADC10\_A module is available on MSP430F51x2 devices. The secondary pin functions Ax (ADC10\_A channel x) available only in MSP430F51x2 devices.

**Table 3. Terminal Functions (continued)**

TERMINAL			I/O <sup>(1)</sup>	DESCRIPTION
NAME	NO.			
	RSB	DA		
P2.1/ PM_TD1.0	14	18	I/O, DV <sub>IO</sub>	General-purpose digital I/O TD1 CCR0 compare output/capture input
P2.2/ PM_TD1.1	15	19	I/O, DV <sub>IO</sub>	General-purpose digital I/O TD1 CCR1 compare output/capture input
P2.3/ PM_TD1.2	16	20	I/O, DV <sub>IO</sub>	General-purpose digital I/O TD1 CCR2 compare output/capture input
DVIO	17	21		5V tolerant digital I/O power supply
DVSS	18	22		Digital ground supply
P2.4/ PM_TEC0CLR/ PM_TEC0FLT2/ PM_TD0.0	19	23	I/O, DV <sub>IO</sub>	General-purpose digital I/O TD0 external clear input/TD0 fault input channel 2 (controlled by module input enable) TD0 CCR0 compare output
P2.5/ PM_TEC0FLT0/ PM_TD0.1	20	24	I/O, DV <sub>IO</sub>	General-purpose digital I/O TD0 fault input channel 0 TD0 CCR1 compare output
P2.6/ PM_TEC0FLT1/ PM_TD0.2	21	25	I/O, DV <sub>IO</sub>	General-purpose digital I/O TD0 fault input channel 1 TD0 CCR2 compare output
P2.7/ PM_TEC1CLR/ PM_TEC1FLT1 PM_TD1.0	22	26	I/O, DV <sub>IO</sub>	General-purpose digital I/O TD1 external clear/TD1 fault input channel 1 (controlled by module input enable) TD1 CCR0 compare output
P3.0/ PM_TEC1FLT2 / PM_TD1.1	23	27	I/O, DV <sub>IO</sub>	General-purpose digital I/O TD1 fault input channel 2 TD1 CCR1 compare output
P3.1/ PM_TEC1FLT0/ PM_TD1.2	24	28	I/O, DV <sub>IO</sub>	General-purpose digital I/O TD1 fault input channel 0 TD1 CCR2 compare output
VCORE	25	29		Regulated core power supply
DVSS	26	30		Digital ground supply
DVCC	27	31		Digital power supply
PJ.6/ TD1CLK/ TD0.1/ CB15	28	32	I/O	General-purpose digital I/O TD1 clock input TD0 CCR1 compare output Comparator_B Input 15
P3.2/ PM_TD0.0/ PM_SMCLK/ CB14	29	33	I/O	General-purpose digital I/O TD0 CCR0 capture input SMCLK output Comparator_B Input 14
P3.3/ PM_TA0CLK/ PM_CBOU/ CB13	30	34	I/O	General-purpose digital I/O TA0 clock input Comparator_B output Comparator_B Input 13
P3.4/ PM_TD0CLK/ PM_MCLK/ (ROSC)	31	-	I/O	General-purpose digital I/O TD0 clock input MCLK output RosC input
TEST/ SBWTCK	32	35		Test mode pin – select digital I/O on JTAG pins Spy-Bi-Wire input clock
RST/ NMI/ SBWTDIO	33	36		Reset input active low Non-maskable interrupt input Spy-bi-wire data input/output

**Table 3. Terminal Functions (continued)**

TERMINAL			I/O <sup>(1)</sup>	DESCRIPTION
NAME	NO.			
	RSB	DA		
P3.5/ PM_TA0.2/ A8 <sup>(3)</sup> / VEREF+/ CB12	34	37	I/O	General-purpose digital I/O TA0 CCR2 compare output/capture input Analog input A8 – 10-bit ADC <sup>(3)</sup> Positive terminal for the ADC's reference voltage for an external applied reference voltage Comparator_B Input 12
P3.6/ PM_TA0.1/ A7 <sup>(3)</sup> / VEREF-/ CB11	35	38	I/O	General-purpose digital I/O TA0 CCR1 compare output/capture input Analog input A7 – 10-bit ADC <sup>(3)</sup> Negative terminal for the ADC's reference voltage for an external applied reference voltage Comparator_B Input 11
P3.7/ PM_TA0.0/ A6 <sup>(3)</sup> / CB10	36	-	I/O	General-purpose digital I/O TA0 CCR0 compare output/capture input Analog input A6 – 10-bit ADC <sup>(3)</sup> Comparator_B Input 10
AVCC	37	1		Analog power supply
PJ.4/ XOUT	38	2	I/O	General-purpose digital I/O Output terminal of crystal oscillator
PJ.5/ XIN	39	3	I/O	General-purpose digital I/O Input terminal for crystal oscillator
AVSS	40	4		Analog ground supply
QFN pad	-	NA		Recommended to connect to DV <sub>SS</sub> externally

(3) The ADC10\_A module is available on MSP430F51x2 devices. The secondary pin functions Ax (ADC10\_A channel x) available only in MSP430F51x2 devices.

## SHORT-FORM DESCRIPTION

### CPU

The MSP430 CPU has a 16-bit RISC architecture that is highly transparent to the application. All operations, other than program-flow instructions, are performed as register operations in conjunction with seven addressing modes for source operand and four addressing modes for destination operand.

The CPU is integrated with 16 registers that provide reduced instruction execution time. The register-to-register operation execution time is one cycle of the CPU clock.

Four of the registers, R0 to R3, are dedicated as program counter, stack pointer, status register, and constant generator, respectively. The remaining registers are general-purpose registers.

Peripherals are connected to the CPU using data, address, and control buses and can be handled with all instructions.

### Instruction Set

The instruction set consists of the original 51 instructions with three formats and seven address modes and additional instructions for the expanded address range. Each instruction can operate on word and byte data. [Table 4](#) shows examples of the three types of instruction formats; [Table 5](#) shows the address modes.

Program Counter	PC/R0
Stack Pointer	SP/R1
Status Register	SR/CG1/R2
Constant Generator	CG2/R3
General-Purpose Register	R4
General-Purpose Register	R5
General-Purpose Register	R6
General-Purpose Register	R7
General-Purpose Register	R8
General-Purpose Register	R9
General-Purpose Register	R10
General-Purpose Register	R11
General-Purpose Register	R12
General-Purpose Register	R13
General-Purpose Register	R14
General-Purpose Register	R15

**Table 4. Instruction Word Formats**

FORMAT	EXAMPLE	OPERATION
Dual operands, source-destination	ADD R4,R5	R4 + R5 → R5
Single operands, destination only	CALL R8	PC → (TOS), R8 → PC
Relative jump, un/conditional	JNE	Jump-on-equal bit = 0

**Table 5. Address Mode Descriptions**

ADDRESS MODE	S <sup>(1)</sup>	D <sup>(1)</sup>	SYNTAX	EXAMPLE	OPERATION
Register	+	+	MOV Rs,Rd	MOV R10,R11	R10 → R11
Indexed	+	+	MOV X(Rn),Y(Rm)	MOV 2(R5),6(R6)	M(2+R5) → M(6+R6)
Symbolic (PC relative)	+	+	MOV EDE,TONI		M(EDE) → M(TONI)
Absolute	+	+	MOV & MEM, & TCDAT		M(MEM) → M(TCDAT)
Indirect	+		MOV @Rn,Y(Rm)	MOV @R10,Tab(R6)	M(R10) → M(Tab+R6)
Indirect autoincrement	+		MOV @Rn+,Rm	MOV @R10+,R11	M(R10) → R11 R10 + 2 → R10
Immediate	+		MOV #X,TONI	MOV #45,TONI	#45 → M(TONI)

(1) S = source, D = destination

## Operating Modes

The MSP430 has one active mode and six software-selectable low-power modes of operation. An interrupt event can wake up the device from any of the five low-power modes, service the request, and restore back to the low-power mode on return from the interrupt program.

The following seven operating modes can be configured by software:

- Active mode (AM)
  - All clocks are active
- Low-power mode 0 (LPM0)
  - CPU is disabled
  - ACLK and SMCLK remain active, MCLK is disabled
  - FLL loop control remains active
- Low-power mode 1 (LPM1)
  - CPU is disabled
  - FLL loop control is disabled
  - ACLK and SMCLK remain active, MCLK is disabled
- Low-power mode 2 (LPM2)
  - CPU is disabled
  - MCLK and FLL loop control and DCOCLK are disabled
  - DCO's dc-generator remains enabled
  - ACLK remains active
- Low-power mode 3 (LPM3)
  - CPU is disabled
  - MCLK, FLL loop control, and DCOCLK are disabled
  - DCO's dc-generator is disabled
  - ACLK remains active
- Low-power mode 4 (LPM4)
  - CPU is disabled
  - ACLK is disabled
  - MCLK, FLL loop control, and DCOCLK are disabled
  - DCO's dc-generator is disabled
  - Crystal oscillator is stopped
  - Complete data retention
- Low-power mode 5 (LPM4.5)
  - Internal regulator disabled
  - No data retention
  - Wakeup from  $\overline{\text{RST}}/\text{NMI}$ , P1, and P2

## Interrupt Vector Addresses

The interrupt vectors and the power-up start address are located in the address range 0FFFFh to 0FF80h. The vector contains the 16-bit address of the appropriate interrupt-handler instruction sequence.

**Table 6. Interrupt Sources, Flags, and Vectors**

INTERRUPT SOURCE	INTERRUPT FLAG	SYSTEM INTERRUPT	WORD ADDRESS	PRIORITY
<b>System Reset</b> Power-Up External Reset Watchdog Timeout, Key Violation Flash Memory Key Violation	WDTIFG, KEYV (SYSRSTIV) <sup>(1) (2)</sup>	Reset	0FFFEh	63, highest
<b>System NMI</b> PMM Vacant Memory Access JTAG Mailbox	SVMLIFG, SVMHIFG, DLYLIFG, DLYHIFG, VLRLIFG, VLRHIFG, VMAIFG, JMBNIFG, JMBOUTIFG (SYSSNIV) <sup>(1)</sup>	(Non)maskable	0FFFCCh	62
<b>User NMI</b> NMI Oscillator Fault Flash Memory Access Violation	NMIIFG, OFIFG, ACCVIFG (SYSUNIV) <sup>(1) (2)</sup>	(Non)maskable	0FFFAh	61
<b>Comp_B</b>	CBIIFG, CBIFG (CBIV) <sup>(1) (3)</sup>	Maskable	0FFF8h	60
<b>TEC0</b>	TEC0FLTIFG, TEC0EXCLRIFG, TEC0AXCLRIFG <sup>(1) (3)</sup>	Maskable	0FFF6h	59
<b>TD0</b>	TD0CCR0 CCIFG0 <sup>(3)</sup>	Maskable	0FFF4h	58
<b>TD0</b>	TD0CCR1 CCIFG1, ... TD0CCR2 CCIFG2, TD0IFG, TD0HFLIFG, TD0HFHIFG, TD0HLKIFG, TD0HUNLKIFG (TD0IV) <sup>(1) (3)</sup>	Maskable	0FFF2h	57
<b>Watchdog Timer_A Interval Timer Mode</b>	WDTIFG	Maskable	0FFF0h	56
<b>USCI_A0 Receive/Transmit</b>	UCA0RXIFG, UCA0TXIFG (UCA0IV) <sup>(1) (3)</sup>	Maskable	0FFEEh	55
<b>USCI_B0 Receive/Transmit</b>	UCB0RXIFG, UCB0TXIFG, I2C Status Interrupt Flags (UCB0IV) <sup>(1) (3)</sup>	Maskable	0FFECCh	54
<b>ADC10_A (MSP430F51x2 only)</b>	ADC10IFG0, ADC10INIFG, ADC10LOIFG, ADC10HIIFG, ADC10TOVIFG, ADC10OVIFG (ADC10IV) <sup>(1) (3)</sup>	Maskable	0FFEAh	53
<b>TA0</b>	TA0CCR0 CCIFG0 <sup>(3)</sup>	Maskable	0FFE8h	52
<b>TA0</b>	TA0CCR1 CCIFG1 ... TA0CCR2 CCIFG2, TA0IFG (TA0IV) <sup>(1) (3)</sup>	Maskable	0FFE6h	51
<b>DMA</b>	DMA0IFG, DMA1IFG, DMA2IFG (DMAIV) <sup>(1) (3)</sup>	Maskable	0FFE4h	50
<b>TEC1</b>	TEC1FLTIFG, TEC1EXCLRIFG, TEC1AXCLRIFG <sup>(1) (3)</sup>	Maskable	0FFE2h	49
<b>TD1</b>	TD1CCR0 CCIFG0 <sup>(3)</sup>	Maskable	0FFE0h	48
<b>TD1</b>	TD1CCR1 CCIFG1 ... TD1CCR2 CCIFG2, TD1IFG, TD1HFLIFG, TD1HFHIFG, TD1HLKIFG, TD1HUNLKIFG (TD1IV) <sup>(1) (3)</sup>	Maskable	0FFDEh	47
<b>I/O Port P1</b>	P1IFG.0 to P1IFG.7 (P1IV) <sup>(1) (3)</sup>	Maskable	0FFDCh	46
<b>I/O Port P2</b>	P2IFG.0 to P2IFG.7 (P2IV) <sup>(1) (3)</sup>	Maskable	0FFDAh	45
<b>Reserved</b>	Reserved <sup>(4)</sup>		0FFD8h	44
			⋮	⋮
			0FF80h	0, lowest

(1) Multiple source flags

(2) A reset is generated if the CPU tries to fetch instructions from within peripheral space or vacant memory space.

(Non)maskable: the individual interrupt-enable bit can disable an interrupt event, but the general-interrupt enable cannot disable it.

(3) Interrupt flags are located in the module.

(4) Reserved interrupt vectors at addresses are not used in this device and can be used for regular program code if necessary. To maintain compatibility with other devices, it is recommended to reserve these locations.

## Memory Organization

		MSP430F5132, MSP430F5131	MSP430F5152, MSP430F5151	MSP430F5172, MSP430F5171
Memory Main: interrupt vector Main: code memory	Size	8KB	16KB	32KB
	Flash	00FFFFh to 00FF80h	00FFFFh to 00FF80h	00FFFFh to 00FF80h
	Flash	00FFFFh to 00E000h	00FFFFh to 00C000h	00FFFFh to 008000h
RAM	Size	1KB	2KB	2KB
	Sector 0	001FFFh to 001C00h	0023FFh to 001C00h	0023FFh to 001C00h
Information memory (Flash)	Size	512 Byte	512 Byte	512 Byte
	Info A	128B 0019FF to 001980h	128B 0019FF to 001980h	128B 0019FF to 001980h
	Info B	128B 00197F to 001900h	128B 00197F to 001900h	128B 00197F to 001900h
	Info C	128B 0018FF to 001880h	128B 0018FF to 001880h	128B 0018FF to 001880h
	Info D	128B 00187F to 001800h	128B 00187F to 001800h	128B 00187F to 001800h
Bootstrap loader (BSL) memory	Size	2K	2KB	2KB
	BSL 3	512B 0017FFh to 001600h	512B 0017FFh to 001600h	512B 0017FFh to 001600h
	BSL 2	512B 0015FFh to 001400h	512B 0015FFh to 001400h	512B 0015FFh to 001400h
	BSL 1	512B 0013FFh to 001200h	512B 0013FFh to 001200h	512B 0013FFh to 001200h
	BSL 0	512B 0011FFh to 001000h	512B 0011FFh to 001000h	512B 0011FFh to 001000h
Peripherals	Size Flash	4KB 000FFFh to 000000h	4KB 000FFFh to 000000h	4KB 000FFFh to 000000h

## Bootstrap Loader (BSL)

The BSL enables users to program the flash memory or RAM using a UART serial interface. Access to the device memory via the BSL is protected by user-defined password. A bootstrap loader security key is provided to disable the BSL completely or to disable the erasure of the flash if an invalid password is supplied. For complete description of the features of the BSL and its implementation, see *MSP430 Programming Via the Bootstrap Loader* (SLAU319).

Table 7. BSL Functions

BSL FUNCTION	DESCRIPTION	
	40-PIN QFN RSB PACKAGE	38-PIN TSSOP DA PACKAGE
RST/NMI/SBWTIO	Entry sequence signal	Entry sequence signal
TEST/SBWTCK	Entry sequence signal	Entry sequence signal
Data transmit	P3.7	P3.5
Data receive	P3.6	P3.6
VCC	Power Supply	Power Supply
VSS	Ground Supply	Ground Supply

## Flash Memory

The flash memory can be programmed via the JTAG port, Spy-Bi-Wire (SBW), the BSL, or in-system by the CPU. The CPU can perform single-byte, single-word, and long-word writes to the flash memory. Features of the flash memory include:

- Flash memory has n segments of main memory and four segments of information memory (A to D) of 128 bytes each. Each segment in main memory is 512 bytes in size.
- Segments 0 to n may be erased in one step, or each segment may be individually erased.
- Segments A to D can be erased individually, or as a group with segments 0 to n. Segments A to D are also called *information memory*.
- Segment A can be locked separately.

## RAM Memory

The RAM memory is made up of n sectors. Each sector can be completely powered down to save leakage; however, all data is lost. Features of the RAM memory include:

- RAM memory has n sectors. The size of a sector can be found in the [Memory Organization](#) section.
- Each sector 0 to n can be complete disabled; however, data retention is lost.
- Each sector 0 to n automatically enters low-power retention mode when possible.

## Peripherals

Peripherals are connected to the CPU through data, address, and control buses and can be handled using all instructions. For complete module descriptions, see the *MSP430x5xx/MSP430x6xx Family User's Guide (SLAU208)*.

## Digital I/O

There are up to three 8-bit I/O ports implemented. Port PJ contains seven individual I/O pins, common to all devices.

- All individual I/O bits are independently programmable.
- Any combination of input, output, and interrupt conditions is possible.
- Programmable pullup or pulldown on all ports.
- Programmable drive strength on all ports.
- Edge-selectable interrupt input capability for all the eight bits of ports P1 and P2.
- Read/write access to port-control registers is supported by all instructions.
- Ports can be accessed byte-wise. P1 and P2 can also be accessed word-wise (PA).
- The input and output voltage levels of the pins supplied by  $DV_{IO}$  (see [Table 3](#)) are defined by the voltage supplied by  $DV_{IO}$  (up to 5V).

## Port Mapping Controller

The port mapping controller allows the flexible and reconfigurable mapping of digital functions to Port P1, Port P2, and Port P3.

**Table 8. Port Mapping, Mnemonics and Functions**

VALUE	PxMAPy MNEMONIC	INPUT PIN FUNCTION	OUTPUT PIN FUNCTION
0	PM_NONE	None	DVSS
1	PM_UCA0CLK	USCI_A0 clock input/output (direction controlled by USCI)	
	PM_UCB0STE	USCI_B0 SPI slave transmit enable (direction controlled by USCI)	
2	PM_UCA0TXD	USCI_A0 UART TXD (Direction controlled by USCI - output)	
	PM_UCA0SIMO	USCI_A0 SPI slave in master out (direction controlled by USCI)	
3	PM_UCB0SOMI	USCI_B0 SPI slave out master in (direction controlled by USCI)	
	PM_UCB0SCL	USCI_B0 I2C clock (open drain and direction controlled by USCI)	
4	PM_UCA0RXD	USCI_A0 UART RXD (Direction controlled by USCI - input)	
	PM_UCA0SOMI	USCI_A0 SPI slave out master in (direction controlled by USCI)	
5	PM_UCB0SIMO	USCI_B0 SPI slave in master out (direction controlled by USCI)	
	PM_UCB0SDA	USCI_B0 I2C data (open drain and direction controlled by USCI)	
6	PM_UCB0CLK	USCI_B0 clock input/output (direction controlled by USCI)	
	PM_UCA0STE	USCI_A0 SPI slave transmit enable (direction controlled by USCI)	
7	PM_TD0.0	TD0 input capture channel 0	TD0 output compare channel 0
8	PM_TD0.1	TD0 input capture channel 1	TD0 output compare channel 1
9	PM_TD0.2	TD0 input capture channel 2	TD0 output compare channel 2
10	PM_TD1.0	TD1 input capture channel 0	TD1 output compare channel 0
11	PM_TD1.1	TD1 input capture channel 1	TD1 output compare channel 1
12	PM_TD1.2	TD1 input capture channel 2	TD1 output compare channel 2
13	PM_CLR1TD0.0	TD0 external clear input	TD0 output compare channel 0
	PM_FLT1_2TD0.0	TD0 fault input channel 2	
14	PM_FLT1_0TD0.1	TD0 fault input channel 0	TD0 output compare channel 1
15	PM_FLT1_1TD0.2	TD0 fault input channel 1	TD0 output compare channel 2
16	PM_CLR2TD1.0	TD1 external clear input (controlled by module input enable)	TD1 output compare channel 0
	PM_FLT2_1TD1.0	TD1 fault input channel 1 (controlled by module input enable)	
17	PM_FLT2_2TD1.1	TD1 fault input channel 2	TD1 output compare channel 1
18	PM_FLT2_0TD1.2	TD1 fault input channel 0	TD1 output compare channel 2
19	PM_TD0.0SMCLK	TD0 input capture channel 0	SMCLK output
20	PM_TA0CLKCBOUT	TA0 input clock	Comparator_B output
21	PM_TD0CLKMCLK	TD0 input clock	MCLK output
22	PM_TA0_0	TA0 input capture channel 0	TA0 output compare channel 0
23	PM_TA0_1	TA0 input capture channel 1	TA0 output compare channel 1
24	PM_TA0_2	TA0 input capture channel 2	TA0 output compare channel 2
25	PM_DMAE0SMCLK	DMAE0 input	SMCLK output
26	PM_DMAE1MCLK	DMAE1 input	MCLK output
27	PM_DMAE2SVM	DMAE2 input	SVM output
28	PM_TD0OUTH	TD0 3-state input	ADC10CLK
29	PM_TD1OUTH	TD1 3-state input	ACLK
30	Reserved	None	DVSS
31 (0FFh) <sup>(1)</sup>	PM_ANALOG	Disables the output driver as well as the input Schmitt-trigger to prevent parasitic cross currents when applying analog signals.	

(1) The value of the PM\_ANALOG mnemonic is set to 0FFh. The port mapping registers are only 5 bits wide and the upper bits are ignored resulting in a read out value of 31.

**Table 9. Default Mapping**

Pin	PxMAPy Mnemonic	Input Pin Function	Output Pin Function
P1.0/PM_UCA0CLK/ PM_UCB0STE/A0/CB0	PM_UCA0CLK PM_UCB0STE	USCI_A0 clock input/output (direction controlled by USCI)	USCI_B0 SPI slave transmit enable (direction controlled by USCI)
P1.1/PM_UCA0TXD/ PM_UCA0SIMO/A1/CB1	PM_UCA0TXD PM_UCA0SIMO	USCI_A0 UART TXD (Direction controlled by USCI - output)	USCI_A0 SPI slave in master out (direction controlled by USCI)
P1.2/PM_UCA0RXD/ PM_UCA0SOMI/A2/CB2	PM_UCA0RXD PM_UCA0SOMI	USCI_A0 UART RXD (Direction controlled by USCI - input)	USCI_A0 SPI slave out master in (direction controlled by USCI)
P1.3/PM_UCB0CLK/ PM_UCA0STE/A3/CB3	PM_UCB0CLK PM_UCA0STE	USCI_B0 clock input/output (direction controlled by USCI)	USCI_A0 SPI slave transmit enable (direction controlled by USCI)
P1.4/PM_UCB0SIMO/ PM_UCB0SDA/A4/CB4	PM_UCB0SIMO PM_UCB0SDA	USCI_B0 SPI slave in master out (direction controlled by USCI)	USCI_B0 I2C data (open drain and direction controlled by USCI)
P1.5/PM_UCB0SOMI/ PM_UCB0SCL/A5/CB5	PM_UCB0SOMI PM_UCB0SCL	USCI_B0 SPI slave out master in (direction controlled by USCI)	USCI_B0 I2C clock (open drain and direction controlled by USCI)
P1.6/PM_TD0.0	PM_TD0.0	TD0 input capture channel 0	TD0 output compare channel 0
P1.7/PM_TD0.1	PM_TD0.1	TD0 input capture channel 1	TD0 output compare channel 1
P2.0/PM_TD0.2	PM_TD0.2	TD0 input capture channel 2	TD0 output compare channel 2
P2.1/PM_TD1.0	PM_TD1.0	TD1 input capture channel 0	TD1 output compare channel 0
P2.2/PM_TD1.1	PM_TD1.1	TD1 input capture channel 1	TD1 output compare channel 1
P2.3/PM_TD1.2	PM_TD1.2	TD1 input capture channel 2	TD1 output compare channel 2
P2.4/PM_TEC0CLR/ PM_TEC0FLT2/PM_TD0.0	PM_CLR1TD0.0 PM_FLT1_2TD0.0	TD0 external clear input (controlled by module input enable) TD0 fault input channel 2 (controlled by module input enable)	TD0 output compare channel 0
P2.5/PM_TEC0FLT0/PM_TD0.1	PM_FLT1_0TD0.1	TD0 fault input channel 0	TD0 output compare channel 1
P2.6/PM_TEC0FLT1/PM_TD0.2	PM_FLT1_1TD0.2	TD0 fault input channel 1	TD0 output compare channel 2
P2.7/PM_TEC1CLR/ PM_TEC1FLT1/PM_TD1.0	PM_CLR2TD1.0 PM_FLT2_1TD1.0	TD1 external clear input (controlled by module input enable) TD1 fault input channel 1 (controlled by module input enable)	TD1 output compare channel 0
P3.0/PM_TEC1FLT2/ PM_TD1.1	PM_FLT2_2TD1.1	TD1 fault input channel 2	TD1 output compare channel 1
P3.1/PM_TEC1FLT0/ PM_TD1.2	PM_FLT2_0TD1.2	TD1 fault input channel 0	TD1 output compare channel 2
P3.2/PM_TD0.0/ PM_SMCLK/CB14	PM_TD0.0SMCLK	TD0 input capture channel 0	SMCLK output
P3.3/PM_TA0CLK/ PM_CBOUT/CB13	PM_TA0CLKCBOUT	TA0 input clock	Comparator_B output
P3.4/PM_TD0CLK/ PM_MCLK/(ROSC)	PM_TD0CLKMCLK	TD0 input clock	MCLK output
P3.5/PM_TA0.2/ VEREF+ /CB12	PM_TA3_2	TA0 input capture channel 0	TA0 output compare channel 0
P3.6/PM_TA0.1/A7 VEREF- /CB11	PM_TA3_1	TA0 input capture channel 1	TA0 output compare channel 1
P3.7/PM_TA0.0/ A6/CB10	PM_TA3_0	TA0 input capture channel 2	TA0 output compare channel 2

## Oscillator and System Clock

The clock system (Unified Clock System, UCS) module includes support for a 32-kHz watch crystal oscillator and high-frequency crystal oscillator, an internal very-low-power low-frequency oscillator (VLO), an internal trimmed low-frequency oscillator (REFO), and an integrated internal digitally controlled oscillator (DCO). The UCS module is designed to meet the requirements of both low system cost and low power consumption. The UCS module features digital frequency locked loop (FLL) hardware that, in conjunction with a digital modulator, stabilizes the DCO frequency to a programmable multiple of the watch crystal frequency. The internal DCO provides a fast turn-on clock source and stabilizes in less than 5  $\mu$ s. The UCS module provides the following clock signals:

- Auxiliary clock (ACLK), sourced from a 32-kHz watch crystal or high-frequency crystal (LFXT1), the internal low-frequency oscillator (VLO), the trimmed low-frequency oscillator (REFO), or the internal digitally-controlled oscillator DCO.
- Main clock (MCLK), the system clock used by the CPU. MCLK can be sourced by same sources available to ACLK.
- Sub-Main clock (SMCLK), the subsystem clock used by the peripheral modules. SMCLK can be sourced by same sources available to ACLK.
- ACLK/n, the buffered output of ACLK, ACLK/2, ACLK/4, ACLK/8, ACLK/16, ACLK/32.

## Power Management Module (PMM)

The PMM includes an integrated voltage regulator that supplies the core voltage to the device and contains programmable output levels to provide for power optimization. The PMM also includes supply voltage supervisor (SVS) and supply voltage monitoring (SVM) circuitry, as well as brownout protection. The brownout circuit is implemented to provide the proper internal reset signal to the device during power-on and power-off. The SVS/SVM circuitry detects if the supply voltage drops below a user-selectable level and supports both supply voltage supervision (the device is automatically reset) and supply voltage monitoring (SVM, the device is not automatically reset). SVS and SVM circuitry is available on the primary supply and core supply.

## Hardware Multiplier

The multiplication operation is supported by a dedicated peripheral module. The module performs operations with 32-bit, 24-bit, 16-bit, and 8-bit operands. The module is capable of supporting signed and unsigned multiplication as well as signed and unsigned multiply and accumulate operations

## Watchdog Timer (WDT\_A)

The primary function of the watchdog timer (WDT\_A) module is to perform a controlled system restart after a software problem occurs. If the selected time interval expires, a system reset is generated. If the watchdog function is not needed in an application, the module can be configured as an interval timer and can generate interrupts at selected time intervals.

## System Module (SYS)

The SYS module handles many of the system functions within the device. These include power-on reset and power-up clear handling, NMI source selection and management, reset interrupt vector generators, bootstrap loader entry mechanisms, and configuration management (device descriptors). It also includes a data exchange mechanism via JTAG called a JTAG mailbox that can be used in the application.

**Table 10. System Module Interrupt Vector Registers**

INTERRUPT VECTOR REGISTER	INTERRUPT EVENT	WORD ADDRESS	OFFSET	PRIORITY
<b>SYSRSTIV , System Reset</b>	No interrupt pending	019Eh	00h	
	Brownout (BOR)		02h	Highest
	RST/NMI (POR)		04h	
	DoBOR (BOR)		06h	
	LPM5 wakeup (BOR)		08h	
	Security violation (BOR)		0Ah	
	SVSL (POR)		0Ch	
	SVSH (POR)		0Eh	
	SVML_OVP (POR)		10h	
	SVMH_OVP (POR)		12h	
	DoPOR (POR)		14h	
	WDT timeout (PUC)		16h	
	WDT key violation (PUC)		18h	
	KEYV flash key violation (PUC)		1Ah	
	FLL unlock (PUC)		1Ch	
	Peripheral area fetch (PUC)		1Eh	
	PMM key violation (PUC)		20h	
Reserved	22h to 3Eh	Lowest		
<b>SYSSNIV , System NMI</b>	No interrupt pending	019Ch	00h	
	SVMLIFG		02h	Highest
	SVMHIFG		04h	
	DLYLIFG		06h	
	DLYHIFG		08h	
	VMAIFG		0Ah	
	JMBINIFG		0Ch	
	JMBOUFIG		0Eh	
	VLRIFG		10h	
	VLRHIFG		12h	
	Reserved		14h to 1Eh	Lowest
	<b>SYSUNIV , User NMI</b>		No interrupt pending	019Ah
NMIFG		02h	Highest	
OFIFG		04h		
ACCVIFG		06h		
Reserved		08h to 1Eh	Lowest	

### DMA Controller

The DMA controller allows movement of data from one memory address to another without CPU intervention. For example, the DMA controller can be used to move data from the ADC10\_A conversion memory to RAM. Using the DMA controller can increase the throughput of peripheral modules. The DMA controller reduces system power consumption by allowing the CPU to remain in sleep mode, without having to wake to move data to or from a peripheral.

**Table 11. DMA Trigger Assignments <sup>(1)</sup>**

Trigger	Channel		
	0	1	2
0	DMAREQ	DMAREQ	DMAREQ
1	TA0CCR0 CCIFG	TA0CCR0 CCIFG	TA0CCR0 CCIFG
2	TA0CCR2 CCIFG	TA0CCR2 CCIFG	TA0CCR2 CCIFG
3	TD0CCR0 CCIFG	TD0CCR0 CCIFG	TD0CCR0 CCIFG
4	TD0CCR2 CCIFG	TD0CCR2 CCIFG	TD0CCR2 CCIFG
5	TD1CCR0 CCIFG	TD1CCR0 CCIFG	TD1CCR0 CCIFG
6	TD1CCR2 CCIFG	TD1CCR2 CCIFG	TD1CCR2 CCIFG
7	Reserved	Reserved	Reserved
8	Reserved	Reserved	Reserved
9	Reserved	Reserved	Reserved
10	Reserved	Reserved	Reserved
11	Reserved	Reserved	Reserved
12	Reserved	Reserved	Reserved
13	Reserved	Reserved	Reserved
14	Reserved	Reserved	Reserved
15	Reserved	Reserved	Reserved
16	UCA0RXIFG	UCA0RXIFG	UCA0RXIFG
17	UCA0TXIFG	UCA0TXIFG	UCA0TXIFG
18	UCB0RXIFG	UCB0RXIFG	UCB0RXIFG
19	UCB0TXIFG	UCB0TXIFG	UCB0TXIFG
20	Reserved	Reserved	Reserved
21	Reserved	Reserved	Reserved
22	Reserved	Reserved	Reserved
23	Reserved	Reserved	Reserved
24	ADC10IFG0	ADC10IFG0	ADC10IFG0
25	Reserved	Reserved	Reserved
26	Reserved	Reserved	Reserved
27	Reserved	Reserved	Reserved
28	Reserved	Reserved	Reserved
29	MPY ready	MPY ready	MPY ready
30	<b>DMA2IFG</b>	<b>DMA0IFG</b>	<b>DMA1IFG</b>
31	DMAE0	DMAE0	DMAE0

(1) Reserved DMA triggers may be used by other devices in the family. Reserved DMA triggers do not cause any DMA trigger event when selected.

## Universal Serial Communication Interface (USCI)

The USCI modules are used for serial data communication. The USCI module supports synchronous communication protocols such as SPI (3 or 4 pin) and I<sup>2</sup>C, and asynchronous communication protocols such as UART, enhanced UART with automatic baudrate detection, and IrDA. Each USCI module contains two modules, A and B.

The USCI\_Ax module provides support for SPI (3 or 4 pin), UART, enhanced UART, or IrDA.

The USCI\_Bx module provides support for SPI (3 or 4 pin) or I<sup>2</sup>C.

## TA0

TA0 is a 16-bit timer/counter with three capture/compare registers. TA0 can support multiple capture/compares, PWM outputs, and interval timing. TA0 also has extensive interrupt capabilities. Interrupts may be generated from the counter on overflow conditions and from each of the capture/compare registers.

**Table 12. TA0 Signal Connections**

INPUT PIN NUMBER		DEVICE INPUT SIGNAL	MODULE INPUT SIGNAL	MODULE BLOCK	MODULE OUTPUT SIGNAL	DEVICE OUTPUT SIGNAL	OUTPUT PIN NUMBER	
RSB (40-PIN QFN)	DA (38-PIN TSSOP)						RSB (40-PIN QFN)	DA (38-PIN TSSOP)
P3.3 - 30	P3.3 - 34	TA0CLK	TACLK	Timer	NA	NA	-	-
ACLK (internal)	ACLK	ACLK	ACLK				-	-
SMCLK (internal)	SMCLK	SMCLK	SMCLK				-	-
P3.3 - 30	P3.3 - 34	TA0CLK	$\overline{\text{TACLK}}$				-	-
P3.7 - 36	-	TA0.0	CCI0A	CCR0	TA0	TA0.0	P3.7 - 36	-
-	-	C Bout	CCI0B				-	-
-	-	V <sub>SS</sub>	GND				-	-
-	-	V <sub>CC</sub>	V <sub>CC</sub>				-	-
P3.6 - 35	-	TA0.1	CCI1A	CCR1	TA1	TA0.1	P3.6 - 35	P3.6 - 38
-	-	ACLK	CCI1B				ADC10_A <sup>(1)</sup> (internal)	ADC10_A <sup>(1)</sup> (internal)
-	-	V <sub>SS</sub>	GND				ADC10SHSx = 001b	ADC10SHSx = 001b
-	-	V <sub>CC</sub>	V <sub>CC</sub>				-	-
P3.5 - 34	P3.5 - 37	TA0.2	CCI2A	CCR2	TA2	TA0.2	P3.5 - 34	P3.5 - 37
-	-	V <sub>SS</sub>	CCI2B				-	-
-	-	V <sub>SS</sub>	GND				-	-
-	-	V <sub>CC</sub>	V <sub>CC</sub>				-	-

(1) The ADC10\_A trigger is available on MSP430F51x2 devices.

**TD0**

TD0 is a 16-bit timer/counter with three capture/compare registers supporting up to 256-MHz / 4-ns resolution. TD0 can support multiple capture/compares, PWM outputs, and interval timing. TD0 also has extensive interrupt capabilities. Interrupts may be generated from the counter on overflow conditions and from each of the capture/compare registers. External fault inputs as well as a external timer counter clear is supported along with interrupt flags from the TEC0 module.

**Table 13. TD0 Signal Connections**

INPUT PIN NUMBER		DEVICE INPUT SIGNAL	MODULE INPUT SIGNAL	MODULE BLOCK	MODULE OUTPUT SIGNAL	DEVICE OUTPUT SIGNAL	OUTPUT PIN NUMBER	
RSB (40-PIN QFN)	DA (38-PIN TSSOP)						RSB (40-PIN QFN)	DA (38-PIN TSSOP)
P3.4 - 31	-	TD0CLK	TDCLK	Timer	NA	NA	-	-
ACLK (internal)	ACLK (internal)	ACLK	ACLK				-	-
SMCLK (internal)	SMCLK (internal)	SMCLK	SMCLK				-	-
P3.4 - 31	-	TD0CLK	$\overline{\text{TDCLK}}$				-	-
-	-	-	CLK0				-	-
P2.4 - 19	P2.4 - 23	TEC0CLR	TECXCLR				-	-
P1.6 - 11 <sup>(1)</sup>	P1.6 - 15 <sup>(1)</sup>	TD0.0	CC10A	CCR0	TD0	TD0	P1.6 - 11 <sup>(1)</sup>	P1.6 - 15 <sup>(1)</sup>
P3.2 - 29	P3.2 - 33	TD0.0	CC10B				P2.4 - 19	P2.4 - 23
-	-	V <sub>SS</sub>	GND				ADC10_A (internal) ADC10SHSx = 010b <sup>(2)</sup>	ADC10_A (internal) ADC10SHSx = 010b <sup>(2)</sup>
-	-	V <sub>CC</sub>	V <sub>CC</sub>				-	-
P2.5 - 20	P2.5 - 24	TEC0FLT0	TECXFLT0				-	-
P1.7 - 12 <sup>(1)</sup>	P1.7 - 16 <sup>(1)</sup>	TD0.1	CC11A	CCR1	TD1	TD1	P1.7 - 12 <sup>(1)</sup>	P1.7 - 16 <sup>(1)</sup>
CBOU (internal)	CBOU (internal)	TD0.1	CC11B				PJ.6 - 28	PJ.6 - 32
-	-	V <sub>SS</sub>	GND				P2.5 - 20	P2.5 - 24
-	-	V <sub>CC</sub>	V <sub>CC</sub>				ADC10_A (internal) ADC10SHSx = 011b <sup>(2)</sup>	ADC10_A (internal) ADC10SHSx = 011b <sup>(2)</sup>
P2.6 - 21	P2.6 - 20	TEC0FLT1	TECXFLT1				-	-
P2.0 - 13 <sup>(1)</sup>	P2.0 - 17 <sup>(1)</sup>	TD0.2	CC12A	CCR2	TD2	TD2	P2.0 - 13 <sup>(1)</sup>	P2.0 - 17 <sup>(1)</sup>
ACLK (internal)	ACLK (internal)	TD0.2	CC12B				P2.6 - 21	P2.6 - 25
-	-	V <sub>SS</sub>	GND				-	-
-	-	V <sub>CC</sub>	V <sub>CC</sub>				-	-
P2.4 - 19	P2.4 - 23	TEC0FLT2	TECXFLT2				-	-

(1) Pins P1.6 for TD0.0, P1.7 for TD0.1, and P2.0 for TD0.2 are optimized for matching.  
(2) The ADC10\_A trigger is available on MSP430F51x2 devices.

**TD1**

TD1 is a 16-bit timer/counter with three capture/compare registers supporting up to 256-MHz / 4-ns resolution. TD1 can support multiple capture/compares, PWM outputs, and interval timing. TD1 also has extensive interrupt capabilities. Interrupts may be generated from the counter on overflow conditions and from each of the capture/compare registers. External fault inputs as well as a external timer counter clear is supported along with interrupt flags from the TEC0 module.

**Table 14. TD1 Signal Connections**

INPUT PIN NUMBER		DEVICE INPUT SIGNAL	MODULE INPUT SIGNAL	MODULE BLOCK	MODULE OUTPUT SIGNAL	DEVICE OUTPUT SIGNAL	OUTPUT PIN NUMBER	
RSB (40-PIN QFN)	DA (38-PIN TSSOP)						RSB (40-PIN QFN)	DA (38-PIN TSSOP)
PJ.6 - 28	PJ.6 - 32	TD1CLK	TDCLK	Timer	NA	NA	-	-
ACLK (internal)	ACLK	ACLK	ACLK				-	-
SMCLK (internal)	SMCLK	SMCLK	SMCLK				-	-
PJ.6 - 28	PJ.6 - 32	TD1CLK	$\overline{\text{TDCLK}}$				-	-
-	-	from TD0 (internal)	CLK0				-	-
P2.7 - 22	P2.7 - 26	TEC1CLR	TECxCLR	CCR0	TD0	TD0	-	-
P2.1 - 14 <sup>(1)</sup>	P2.1 - 18 <sup>(1)</sup>	TD1.0	CCI0A				P2.1 - 14 <sup>(1)</sup>	P2.1 - 18 <sup>(1)</sup>
-	-	TD1.0	CCI0B				P2.7 - 22	P2.7 - 26
-	-	V <sub>SS</sub>	GND				-	-
-	-	V <sub>CC</sub>	V <sub>CC</sub>				-	-
P3.1 - 24	P3.1 - 28	TEC1FLT0	TECXFLT0	CCR1	TD1	TD1	-	-
P2.2 - 15 <sup>(1)</sup>	P2.2 - 19 <sup>(1)</sup>	TD1.1	CCI1A				P2.2 - 15 <sup>(1)</sup>	P2.2 - 19 <sup>(1)</sup>
CBOU (internal)	CBOU (internal)	TD1.1	CCI1B				P3.0 - 23	P3.0 - 27
-	-	V <sub>SS</sub>	GND				-	-
-	-	V <sub>CC</sub>	V <sub>CC</sub>				-	-
P2.7 - 22	P2.7 - 26	TEC1FLT1	TECXFLT1	CCR2	TD2	TD2	-	-
P2.3 - 16 <sup>(1)</sup>	P2.3 - 20 <sup>(1)</sup>	TD1.2	CCI2A				P2.3 - 16 <sup>(1)</sup>	P2.3 - 20 <sup>(1)</sup>
ACLK (internal)	ACLK (internal)	TD1.2	CCI2B				P3.1 - 24	P3.1 - 28
-	-	V <sub>SS</sub>	GND				-	-
-	-	V <sub>CC</sub>	V <sub>CC</sub>				-	-
P3.0 - 23	P3.0 - 27	TEC1FLT2	TECXFLT2				-	-

(1) Pins P2.1 for TD1.0, P2.2 for TD1.1, and P2.3 for TD1.2 are optimized for matching.

## **Comparator\_B**

The primary function of the Comparator\_B module is to support precision slope analog-to-digital conversions, battery voltage supervision, and monitoring of external analog signals.

## **ADC10\_A (MSP430F51x2 Only)**

The ADC10\_A module supports fast, 10-bit analog-to-digital conversions. The module implements a 10-bit SAR core, sample select control, reference generator and a conversion result buffer. A window comparator with a lower and upper limit allows CPU independent result monitoring with three window comparator interrupt flags.

## **CRC16**

The CRC16 module produces a signature based on a sequence of entered data values and can be used for data checking purposes. The CRC16 module signature is based on the CRC-CCITT standard.

## **REF Voltage Reference**

The reference module (REF) is responsible for generation of all critical reference voltages that can be used by the various analog peripherals in the device.

## **Embedded Emulation Module (EEM) (S Version)**

The Embedded Emulation Module (EEM) supports real-time in-system debugging. The S version of the EEM implemented on all devices has the following features:

- Three hardware triggers/breakpoints on memory access
- One hardware trigger/breakpoint on CPU register write access
- Up to four hardware triggers can be combined to form complex triggers/breakpoints
- One cycle counter
- Clock control on module level

**Peripheral File Map**
**Table 15. Peripherals**

MODULE NAME	BASE ADDRESS	OFFSET ADDRESS RANGE
Special Functions (see <a href="#">Table 16</a> )	0100h	000h - 01Fh
PMM (see <a href="#">Table 17</a> )	0120h	000h - 00Fh
Flash Control (see <a href="#">Table 18</a> )	0140h	000h - 00Fh
CRC16 (see <a href="#">Table 19</a> )	0150h	000h - 007h
RAM Control (see <a href="#">Table 20</a> )	0158h	000h - 001h
Watchdog (see <a href="#">Table 21</a> )	015Ch	000h - 001h
UCS (see <a href="#">Table 22</a> )	0160h	000h - 01Fh
SYS (see <a href="#">Table 23</a> )	0180h	000h - 01Fh
Shared Reference (see <a href="#">Table 24</a> )	01B0h	000h - 001h
Port Mapping Control (see <a href="#">Table 25</a> )	01C0h	000h - 007h
Port Mapping Port P1 (see <a href="#">Table 26</a> )	01C8h	000h - 007h
Port Mapping Port P2 (see <a href="#">Table 27</a> )	01D0h	000h - 007h
Port Mapping Port P3 (see <a href="#">Table 28</a> )	01D8h	000h - 007h
Port P1/P2 (see <a href="#">Table 29</a> )	0200h	000h - 01Fh
Port P3 (see <a href="#">Table 30</a> )	0220h	000h - 01Fh
Port PJ (see <a href="#">Table 31</a> )	0320h	000h - 01Fh
TA0 (see <a href="#">Table 32</a> )	03C0h	000h - 03Fh
32-bit Hardware Multiplier (see <a href="#">Table 33</a> )	04C0h	000h - 02Fh
DMA General Control (see <a href="#">Table 34</a> )	0500h	000h - 00Fh
DMA Channel 0 (see <a href="#">Table 35</a> )	0500h	010h - 00Ah
DMA Channel 1 (see <a href="#">Table 36</a> )	0500h	020h - 00Ah
DMA Channel 2 (see <a href="#">Table 37</a> )	0500h	030h - 00Ah
USCI_A0 (see <a href="#">Table 38</a> )	05C0h	000h - 01Fh
USCI_B0 (see <a href="#">Table 38</a> )	05E0h	000h - 01Fh
ADC10_A (see <a href="#">Table 40</a> ) (MSP430F51x2 only)	0740h	000h - 01Fh
Comparator_B (see <a href="#">Table 41</a> )	08C0h	000h - 00Fh
TD0 (see <a href="#">Table 42</a> )	0B00h	000h - 03Fh
TEC0 (see <a href="#">Table 44</a> )	0C00h	000h - 007h
TD1 (see <a href="#">Table 43</a> )	0B40h	000h - 03Fh
TEC1 (see <a href="#">Table 45</a> )	0C20h	000h - 007h

**Table 16. Special Function Registers (Base Address: 0100h)**

REGISTER DESCRIPTION	REGISTER	OFFSET
SFR interrupt enable	SFRIE1	00h
SFR interrupt flag	SFRIFG1	02h
SFR reset pin control	SFRRPCR	04h

**Table 17. PMM Registers (Base Address: 0120h)**

REGISTER DESCRIPTION	REGISTER	OFFSET
PMM Control 0	PMMCTL0	00h
PMM control 1	PMMCTL1	02h
SVS high side control	SVSMHCTL	04h
SVS low side control	SVSMLCTL	06h
PMM interrupt flags	PMMIFG	0Ch
PMM interrupt enable	PMMIE	0Eh
PMM Power Mode 5 control register 0	PMM5CTL0	10h

**Table 18. Flash Control Registers (Base Address: 0140h)**

REGISTER DESCRIPTION	REGISTER	OFFSET
Flash control 1	FCTL1	00h
Flash control 3	FCTL3	04h
Flash control 4	FCTL4	06h

**Table 19. CRC16 Registers (Base Address: 0150h)**

REGISTER DESCRIPTION	REGISTER	OFFSET
CRC data input	CRC16DI	00h
CRC result	CRC16NIRE	04h

**Table 20. RAM Control Registers (Base Address: 0158h)**

REGISTER DESCRIPTION	REGISTER	OFFSET
RAM control 0	RCCTL0	00h

**Table 21. Watchdog Registers (Base Address: 015Ch)**

REGISTER DESCRIPTION	REGISTER	OFFSET
Watchdog timer control	WDTCTL	00h

**Table 22. UCS Registers (Base Address: 0160h)**

REGISTER DESCRIPTION	REGISTER	OFFSET
UCS control 0	UCSCTL0	00h
UCS control 1	UCSCTL1	02h
UCS control 2	UCSCTL2	04h
UCS control 3	UCSCTL3	06h
UCS control 4	UCSCTL4	08h
UCS control 5	UCSCTL5	0Ah
UCS control 6	UCSCTL6	0Ch
UCS control 7	UCSCTL7	0Eh
UCS control 8	UCSCTL8	10h

**Table 23. SYS Registers (Base Address: 0180h)**

REGISTER DESCRIPTION	REGISTER	OFFSET
System control	SYSCCTL	00h
Bootstrap loader configuration area	SYSBSLC	02h
JTAG mailbox control	SYSJMBC	06h
JTAG mailbox input 0	SYSJMBIO	08h
JTAG mailbox input 1	SYSJMBI1	0Ah
JTAG mailbox output 0	SYSJMBO0	0Ch
JTAG mailbox output 1	SYSJMBO1	0Eh
Bus Error vector generator	SYSBERRIV	18h
User NMI vector generator	SYSUNIV	1Ah
System NMI vector generator	SYSSNIV	1Ch
Reset vector generator	SYSRSTIV	1Eh

**Table 24. Shared Reference Registers (Base Address: 01B0h)**

REGISTER DESCRIPTION	REGISTER	OFFSET
Shared reference control	REFCTL	00h

**Table 25. Port Mapping Controller (Base Address: 01C0h)**

REGISTER DESCRIPTION	REGISTER	OFFSET
Port mapping password register	PMAPPWD	00h
Port mapping control register	PMAPCTL	02h

**Table 26. Port Mapper for Port P1 (Base Address: 01C8h)**

REGISTER DESCRIPTION	REGISTER	OFFSET
Port P1.0 mapping register	P1MAP0	00h
Port P1.1 mapping register	P1MAP1	01h
Port P1.2 mapping register	P1MAP2	02h
Port P1.3 mapping register	P1MAP3	03h
Port P1.4 mapping register	P1MAP4	04h
Port P1.5 mapping register	P1MAP5	05h
Port P1.6 mapping register	P1MAP6	06h
Port P1.7 mapping register	P1MAP7	07h

**Table 27. Port Mapper for Port P2 (Base Address: 01D0h)**

REGISTER DESCRIPTION	REGISTER	OFFSET
Port P2.0 mapping register	P2MAP0	00h
Port P2.1 mapping register	P2MAP2	01h
Port P2.2 mapping register	P2MAP2	02h
Port P2.3 mapping register	P2MAP3	03h
Port P2.4 mapping register	P2MAP4	04h
Port P2.5 mapping register	P2MAP5	05h
Port P2.6 mapping register	P2MAP6	06h
Port P2.7 mapping register	P2MAP7	07h

**Table 28. Port Mapper for Port P3 (Base Address: 01D8h)**

REGISTER DESCRIPTION	REGISTER	OFFSET
Port P3.0 mapping register	P3MAP0	00h
Port P3.1 mapping register	P3MAP1	01h
Port P3.2 mapping register	P3MAP2	02h
Port P3.3 mapping register	P3MAP3	03h
Port P3.4 mapping register	P3MAP4	04h
Port P3.5 mapping register	P3MAP5	05h
Port P3.6 mapping register	P3MAP6	06h
Port P3.7 mapping register	P3MAP7	07h

**Table 29. Port Registers Port P1/P2 (Base Addresses: 0200h)**

REGISTER DESCRIPTION	REGISTER	OFFSET
Port P1 input	P1IN	00h
Port P1 output	P1OUT	02h
Port P1 direction	P1DIR	04h
Port P1 pullup/pulldown enable	P1REN	06h
Port P1 drive strength	P1DS	08h
Port P1 selection	P1SEL	0Ah
Port P1 interrupt vector word	P1IV	0Eh
Port P1 interrupt edge select	P1IES	18h
Port P1 interrupt enable	P1IE	1Ah
Port P1 interrupt flag	P1IFG	1Ch
Port P2 input	P2IN	01h
Port P2 output	P2OUT	03h
Port P2 direction	P2DIR	05h
Port P2 pullup/pulldown enable	P2REN	07h
Port P2 drive strength	P2DS	09h
Port P2 selection	P2SEL	0Bh
Port P2 interrupt vector word	P2IV	1Eh
Port P2 interrupt edge select	P2IES	19h
Port P2 interrupt enable	P2IE	1Bh
Port P2 interrupt flag	P2IFG	1Dh

**Table 30. Port Registers P3 (Base Addresses: 0220h)**

REGISTER DESCRIPTION	REGISTER	OFFSET
Port P3 input	P3IN	00h
Port P3 output	P3OUT	02h
Port P3 direction	P3DIR	04h
Port P3 pullup/pulldown enable	P3REN	06h
Port P3 drive strength	P3DS	08h
Port P3 selection	P3SEL	0Ah

**Table 31. Port Registers PJ (Base Addresses: 0320h)**

REGISTER DESCRIPTION	REGISTER	OFFSET
Port PJ input	PJIN	00h
Port PJ output	PJOUT	02h
Port PJ direction	PJDIR	04h
Port PJ pullup/pulldown enable	PJREN	06h
Port PJ drive strength	PJDS	08h
Port PJ selection	PJSEL	0Ah

**Table 32. TA0 Registers (Base Address: 03C0h)**

REGISTER DESCRIPTION	REGISTER	OFFSET
TA0 control	TAOCTL	00h
Capture/compare control 0	TAOCTL0	02h
Capture/compare control 1	TAOCTL1	04h
Capture/compare control 2	TAOCTL2	06h
TA0 counter register	TAOR	10h
Capture/compare register 0	TAOCCR0	12h
Capture/compare register 1	TAOCCR1	14h
Capture/compare register 2	TAOCCR2	16h
TA0 expansion register 0	TAOEX0	20h
TA0 interrupt vector	TAOIV	2Eh

**Table 33. 32-bit Hardware Multiplier Registers (Base Address: 04C0h)**

REGISTER DESCRIPTION	REGISTER	OFFSET
16-bit operand 1 – multiply	MPY	00h
16-bit operand 1 – signed multiply	MPYS	02h
16-bit operand 1 – multiply accumulate	MAC	04h
16-bit operand 1 – signed multiply accumulate	MACS	06h
16-bit operand 2	OP2	08h
16 × 16 result low word	RESLO	0Ah
16 × 16 result high word	RESHI	0Ch
16 × 16 sum extension register	SUMEXT	0Eh
32-bit operand 1 – multiply low word	MPY32L	10h
32-bit operand 1 – multiply high word	MPY32H	12h
32-bit operand 1 – signed multiply low word	MPYS32L	14h
32-bit operand 1 – signed multiply high word	MPYS32H	16h
32-bit operand 1 – multiply accumulate low word	MAC32L	18h
32-bit operand 1 – multiply accumulate high word	MAC32H	1Ah
32-bit operand 1 – signed multiply accumulate low word	MACS32L	1Ch
32-bit operand 1 – signed multiply accumulate high word	MACS32H	1Eh
32-bit operand 2 – low word	OP2L	20h
32-bit operand 2 – high word	OP2H	22h
32 × 32 result 0 – least significant word	RES0	24h
32 × 32 result 1	RES1	26h
32 × 32 result 2	RES2	28h
32 × 32 result 3 – most significant word	RES3	2Ah
MPY32 control register 0	MPY32CTL0	2Ch

**Table 34. DMA General Control (Base Address: 0500h)**

REGISTER DESCRIPTION	REGISTER	OFFSET
DMA module control 0	DMACTL0	00h
DMA module control 1	DMACTL1	02h
DMA module control 2	DMACTL2	04h
DMA module control 3	DMACTL3	06h
DMA module control 4	DMACTL4	08h
DMA interrupt vector	DMAIV	0Eh

**Table 35. DMA Channel 0 (Base Address: 0510h)**

REGISTER DESCRIPTION	REGISTER	OFFSET
DMA channel 0 control	DMA0CTL	00h
DMA channel 0 source address low	DMA0SAL	02h
DMA channel 0 source address high	DMA0SAH	04h
DMA channel 0 destination address low	DMA0DAL	06h
DMA channel 0 destination address high	DMA0DAH	08h
DMA channel 0 transfer size	DMA0SZ	0Ah

**Table 36. DMA Channel 1 (Base Address: 0520h)**

REGISTER DESCRIPTION	REGISTER	OFFSET
DMA channel 1 control	DMA1CTL	00h
DMA channel 1 source address low	DMA1SAL	02h
DMA channel 1 source address high	DMA1SAH	04h
DMA channel 1 destination address low	DMA1DAL	06h
DMA channel 1 destination address high	DMA1DAH	08h
DMA channel 1 transfer size	DMA1SZ	0Ah

**Table 37. DMA Channel 2 (Base Address: 0530h)**

REGISTER DESCRIPTION	REGISTER	OFFSET
DMA channel 2 control	DMA2CTL	00h
DMA channel 2 source address low	DMA2SAL	02h
DMA channel 2 source address high	DMA2SAH	04h
DMA channel 2 destination address low	DMA2DAL	06h
DMA channel 2 destination address high	DMA2DAH	08h
DMA channel 2 transfer size	DMA2SZ	0Ah

**Table 38. USCI0\_A Registers (Base Address: 05C0h)**

REGISTER DESCRIPTION	REGISTER	OFFSET
USCI control 0	UCA0CTL0	01h
USCI control 1	UCA0CTL1	00h
USCI baud rate 0	UCA0BR0	06h
USCI baud rate 1	UCA0BR1	07h
USCI modulation control	UCA0MCTL	08h
USCI status	UCA0STAT	0Ah
USCI receive buffer	UCA0RXBUF	0Ch
USCI transmit buffer	UCA0TXBUF	0Eh
USCI LIN control	UCA0ABCTL	10h
USCI IrDA transmit control	UCA0IRTCTL	12h
USCI IrDA receive control	UCA0IRRCTL	13h
USCI interrupt enable	UCA0IE	1Ch
USCI interrupt flags	UCA0IFG	1Dh
USCI interrupt vector word	UCA0IV	1Eh

**Table 39. USCI0\_B Registers (Base Address: 05E0h)**

REGISTER DESCRIPTION	REGISTER	OFFSET
USCI synchronous control 0	UCB0CTL0	00h
USCI synchronous control 1	UCB0CTL1	01h
USCI synchronous bit rate 0	UCB0BR0	06h
USCI synchronous bit rate 1	UCB0BR1	07h
USCI synchronous status	UCB0STAT	0Ah
USCI synchronous receive buffer	UCB0RXBUF	0Ch
USCI synchronous transmit buffer	UCB0TXBUF	0Eh
USCI I2C own address	UCB0I2COA	10h
USCI I2C slave address	UCB0I2CSA	12h
USCI interrupt enable	UCB0IE	1Ch
USCI interrupt flags	UCB0IFG	1Dh
USCI interrupt vector word	UCB0IV	1Eh

**Table 40. ADC10\_A Registers (MSP430F51x2 Devices Only) (Base Address: 0740h)**

REGISTER DESCRIPTION	REGISTER	OFFSET
ADC10_A Control register 0	ADC10CTL0	00h
ADC10_A Control register 1	ADC10CTL1	02h
ADC10_A Control register 2	ADC10CTL2	04h
ADC10_A Window Comparator Low Threshold	ADC10LO	06h
ADC10_A Window Comparator High Threshold	ADC10HI	08h
ADC10_A Memory Control Register 0	ADC10MCTL0	0Ah
ADC10_A Conversion Memory Register	ADC10MEM0	12h
ADC10_A Interrupt Enable	ADC10IE	1Ah
ADC10_A Interrupt Flags	ADC10IGH	1Ch
ADC10_A Interrupt Vector Word	ADC10IV	1Eh

**Table 41. Comparator\_B Registers (Base Address: 08C0h)**

REGISTER DESCRIPTION	REGISTER	OFFSET
Comparator_B control register 0	CBCTL0	00h
Comparator_B control register 1	CBCTL1	02h
Comparator_B control register 2	CBCTL2	04h
Comparator_B control register 3	CBCTL3	06h
Comparator_B interrupt register	CBINT	0Ch
Comparator_B interrupt vector word	CBIV	0Eh

**Table 42. TD0 Registers (Base Address: 0B00h)**

REGISTER DESCRIPTION	REGISTER	OFFSET
TD0 Control 0	TD0CTL0	00h
TD0 Control 1	TD0CTL1	02h
TD0 Control 2	TD0CTL2	04h
TD0 Counter Register	TD0R	06h
Capture/compare control 0	TD0CCTL0	08h
Capture/compare register 0	TD0CCR0	0Ah
Capture/compare Latch 0	TD0CL0	0Ch
Capture/compare control 1	TD0CCTL1	0Eh
Capture/compare register 1	TD0CCR1	10h
Capture/compare Latch 1	TD0CL1	12h
Capture/compare control 2	TD0CCTL2	14h
Capture/compare register 2	TD0CCR2	16h
Capture/compare Latch 2	TD0CL2	18h
TD0 High-Resolution Control 0	TD0HCTL0	38h
TD0 High-Resolution Control 1	TD0HCTL1	3Ah
TD0 High-Resolution Interrupt	TD0HINT	3Ch
TD0 Interrupt Vector	TD0IV	3Eh

**Table 43. TD1 Registers (Base Address: 0B40h)**

REGISTER DESCRIPTION	REGISTER	OFFSET
TD1 Control 0	TD1CTL0	00h
TD1 Control 1	TD1CTL1	02h
TD1 Control 2	TD1CTL2	04h
TD1 Counter Register	TD1R	06h
Capture/compare control 0	TD1CCTL0	08h
Capture/compare register 0	TD1CCR0	0Ah
Capture/compare Latch 0	TD1CL0	0Ch
Capture/compare control 1	TD1CCTL1	0Eh
Capture/compare register 1	TD1CCR1	10h
Capture/compare Latch 1	TD1CL1	12h
Capture/compare control 2	TD1CCTL2	14h
Capture/compare register 2	TD1CCR2	16h
Capture/compare Latch 2	TD1CL2	18h
TD1 High-Resolution Control 0	TD1HCTL0	38h
TD1 High-Resolution Control 1	TD1HCTL1	3Ah
TD1 High-Resolution Interrupt	TD1HINT	3Ch
TD1 Interrupt Vector	TD1IV	3Eh

**Table 44. TEC0 Registers (Base Address: 0C00h)**

REGISTER DESCRIPTION	REGISTER	OFFSET
Timer Event Control 0 External Control 0	TECOCTL0	00h
Timer Event Control 0 External Control	TECOCTL1	02h
Timer Event Control 0 External Control	TECOCTL2	04h
Timer Event Control 0 Status	TECOSTA	06h
Timer Event Control 0 External Interrupt	TECOXINT	08h
Timer Event Control 0 External Interrupt Vector	TECOIV	0Ah

**Table 45. TEC1 Registers (Base Address: 0C20h)**

REGISTER DESCRIPTION	REGISTER	OFFSET
Timer Event Control 1 External Control 0	TEC1CTL0	00h
Timer Event Control 1 External Control	TEC1CTL1	02h
Timer Event Control 1 External Control	TEC1CTL2	04h
Timer Event Control 1 Status	TEC1STA	06h
Timer Event Control 1 External Interrupt	TEC1XINT	08h
Timer Event Control 1 External Interrupt Vector	TEC1IV	0Ah

### Absolute Maximum Ratings<sup>(1)</sup>

over operating free-air temperature range (unless otherwise noted)

Voltage $V_{CC}$ applied at DVCC to DVSS	–0.3 V to 4.1 V
Voltage $V_{IO}$ applied at VIO to DVSS	–0.3 V to 6.1 V
Voltage applied to any pin (excluding V <sub>CORE</sub> ) <sup>(2)</sup>	–0.3 V to $V_{CC} + 0.3$ V
Diode current at any device pin	±2 mA
Storage temperature range, $T_{stg}$	–55°C to 150°C
Maximum operating junction temperature, $T_J$	95°C

- (1) Stresses beyond those listed under "absolute maximum ratings" may cause permanent damage to the device. These are stress ratings only, and functional operation of the device at these or any other conditions beyond those indicated under "recommended operating conditions" is not implied. Exposure to absolute-maximum-rated conditions for extended periods may affect device reliability.
- (2) All voltages referenced to  $V_{SS}$ .  $V_{CORE}$  is for internal device usage only. No external DC loading or voltage should be applied.

### Thermal Packaging Characteristics

$\theta_{JA}$ Junction-to-ambient thermal resistance, still air	Low-K board (JESD51-3)	QFN (RSB)	87°C/W
		TSSOP (DA)	109°C/W
	High-K board (JESD51-7)	QFN (RSB)	35°C/W
		TSSOP (DA)	69°C/W
$\theta_{JC}$ Junction-to-case thermal resistance		QFN (RSB)	36°C/W
		TSSOP (DA)	19°C/W

## Recommended Operating Conditions

		MIN	NOM	MAX	UNIT
V <sub>CC</sub>	Supply voltage during program execution and flash programming V(AVCC) = V(DVCC) = V <sub>CC</sub> <sup>(1)</sup>	PMMCOREVx = 0	1.8	3.6	V
		PMMCOREVx = 0, 1	2.0	3.6	V
		PMMCOREVx = 0, 1, 2	2.2	3.6	V
		PMMCOREVx = 0, 1, 2, 3	2.4	3.6	V
V <sub>IO</sub>	Supply voltage of pins P1.6, P1.7, P2.0 to P2.7, P3.0, and P3.1 supplied by V <sub>IO</sub> <sup>(2)</sup>	1.8		5.5	V
V <sub>SS</sub>	Supply voltage V(AVSS) = V(DVSS) = V <sub>SS</sub>		0		V
T <sub>A</sub>	Operating free-air temperature	–40		85	°C
T <sub>J</sub>	Operating junction temperature	–40		85	°C
C(VCORE)	Recommended capacitor at V <sub>CORE</sub>		470		nF
C(DVCC)/C(VCORE)	Capacitor ratio of DVCC to V <sub>CORE</sub>	10			
f <sub>SYSTEM</sub>	Processor frequency (maximum MCLK frequency) <sup>(3)</sup> <sup>(4)</sup> (see <a href="#">Figure 1</a> )	PMMCOREVx = 0, 1.8 V ≤ V <sub>CC</sub> ≤ 3.6 V (default condition)	0	12	MHz
		PMMCOREVx = 1, 2.0 V ≤ V <sub>CC</sub> ≤ 3.6 V	0	16	
		PMMCOREVx = 2, 2.2 V ≤ V <sub>CC</sub> ≤ 3.6 V	0	20	
		PMMCOREVx = 3, 2.4 V ≤ V <sub>CC</sub> ≤ 3.6 V	0	25	
P <sub>INT</sub>	Internal power dissipation		V <sub>CC</sub> × I(DVCC)		W
P <sub>IO</sub>	I/O power dissipation of the I/O pins powered by DVCC		$(V_{CC} - V_{IOH}) \times I_{IOH} + V_{IOL} \times I_{IOL}$		W
P <sub>IO5</sub>	I/O power dissipation of the I/O pins powered by V <sub>IO</sub>		$(V_{IO} - V_{IOH5}) \times I_{IOH5} + V_{IOL5} \times I_{IOL5}$		W
P <sub>MAX</sub>	Maximum allowed power dissipation, P <sub>MAX</sub> > P <sub>IO</sub> + P <sub>IO5</sub> + P <sub>INT</sub>		(T <sub>J</sub> - T <sub>A</sub> )/θ <sub>JA</sub>		W

- (1) It is recommended to power AVCC and DVCC from the same source. A maximum difference of 0.3 V between V(AVCC) and V(DVCC) can be tolerated during power up and operation.
- (2) It is recommended to power DVCC and AVCC prior to DVIO. At DVCC/AVCC voltages higher than 1.8 V, the maximum difference of 0.3 V between DVIO and DVCC/AVCC can be exceeded.
- (3) The MSP430 CPU is clocked directly with MCLK. Both the high and low phase of MCLK must not exceed the pulse width of the specified maximum frequency.
- (4) Modules may have a different maximum input clock specification. See the specification of the respective module in this data sheet.

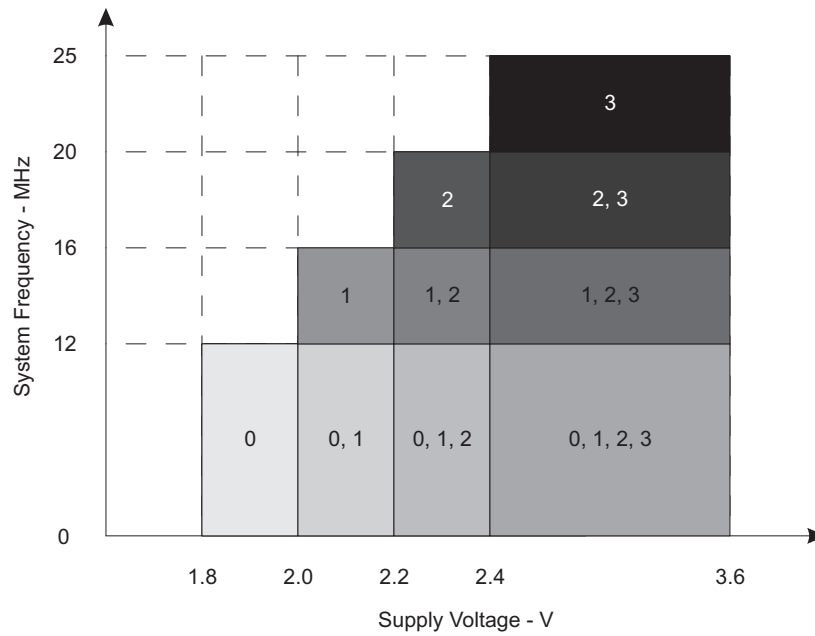

The numbers within the fields denote the supported PMMCOREVx settings.

**Figure 1. Frequency vs Supply Voltage**

## Electrical Characteristics

### Active Mode Supply Current Into $V_{CC}$ Excluding External Current

over recommended ranges of supply voltage and operating free-air temperature (unless otherwise noted)

PARAMETER	EXECUTION MEMORY	$V_{CC}$	PMM CORE $V_x$	FREQUENCY ( $f_{DCO} = f_{MCLK} = f_{SMCLK}$ )										UNIT
				1 MHz		8 MHz		12 MHz		20 MHz		25 MHz		
				TYP	MAX	TYP	MAX	TYP	MAX	TYP	MAX	TYP	MAX	
$I_{AM, Flash}$	Flash	3 V	0	0.24	0.27	1.48	1.60	-	-	-	-	-	-	mA
			1	0.26	-	1.66	-	2.48	2.7	-	-	-	-	
			2	0.28	-	1.83	-	2.72	-	4.50	4.8	-	-	
			3	0.28	-	1.83	-	2.66	-	4.40	-	5.60	6.15	
$I_{AM, RAM}$	RAM	3 V	0	0.17	0.2	0.89	0.97	-	-	-	-	-	-	mA
			1	0.18	-	1.00	-	1.49	1.62	-	-	-	-	
			2	0.20	-	1.14	-	1.68	-	2.75	3.0	-	-	
			3	0.20	-	1.20	-	1.78	-	2.92	-	3.64	4.0	

### Low-Power Mode Supply Currents (Into $V_{CC}$ ) Excluding External Current

over recommended ranges of supply voltage and operating free-air temperature (unless otherwise noted)<sup>(1) (2)</sup>

PARAMETER	$V_{CC}$	PMM CORE $V_x$	-40°C		25°C		60°C		85°C		UNIT
			TYP	MAX	TYP	MAX	TYP	MAX	TYP	MAX	
$I_{LPM0, 1MHz}$ Low-power mode 0	2.2 V	0	82	90	85	90	87	95	85	100	μA
	3 V	3	88	100	85	100	90	104	88	104	
$I_{LPM2}$ Low-power mode 2	2.2 V	0	10	12.5	10	12	10	12.5	12.5	13	μA
	3 V	3	9	11.5	11	13	11	15	12	14	
$I_{LPM3, XT1LF}$ Low-power mode 3, crystal mode	2.2 V	0	1.7	-	1.8	2.0	2.5	-	3.5	4.5	μA
	3 V		2.0	-	2.0	2.2	3.0	-	3.7	4.5	
	2.2 V	1	1.8	-	1.9	-	2.5	-	4.0	-	
	3 V		2.1	-	2.2	-	2.5	-	4.0	-	
	2.2 V	2	1.8	-	2.0	-	2.5	-	4.2	-	
	3 V		2.0	-	2.2	-	2.8	-	4.2	-	
	2.2 V	3	1.9	-	2.0	2.5	2.9	-	3.9	5.0	
	3 V		2.1	-	2.2	2.5	3.0	-	4.0	5.5	
$I_{LPM3, VLO}$ Low-power mode 3, VLO mode	2.2 V	0	1.0	-	1.0	1.25	1.6	-	2.7	3.5	μA
	3 V		1.1	-	1.2	1.4	1.5	-	2.8	4.0	
	2.2 V	1	1.0	-	1.1	-	1.8	-	3.0	-	
	3 V		1.3	-	1.1	-	2.0	-	3.2	-	
	2.2 V	2	1.1	-	1.1	-	1.8	-	3.1	-	
	3 V		1.1	-	1.2	-	2.0	-	3.2	-	
	2.2 V	3	1.1	-	1.1	1.4	1.9	-	3.0	4.0	
	3 V		1.1	-	1.2	1.5	2.1	-	3.0	4.5	
$I_{LPM4}$ Low-power mode 4	3 V	0	0.8	-	0.9	1.3	1.4	-	2.7	3.7	μA
		1	0.8	-	1.0	-	1.4	-	3.0	-	
		2	0.8	-	1.0	-	1.5	-	3.0	-	
		3	0.9	-	1.0	1.3	1.6	-	3.0	4.0	
$I_{LPM4.5}$ Low-power mode 4.5	2.2 V	x	0.06	-	0.20	0.26	0.33	-	0.60	0.9	μA
	3 V	x	0.07	-	0.25	0.29	0.37	-	0.77	0.9	

(1) All inputs are tied to 0 V or to  $V_{CC}$ . Outputs do not source or sink any current. DVIO = DVCC = AVCC.

(2) The currents are characterized with a Micro Crystal MS1V-T1K SMD crystal with a load capacitance of 12.5 pF. The internal and external load capacitance are chosen to closely match the required 9 pF.

### Schmitt-Trigger Inputs – General Purpose I/O (P1.0 to P1.5, P3.2 to P3.7, and PJ.0 to PJ.6)

over recommended ranges of supply voltage and operating free-air temperature (unless otherwise noted)

PARAMETER		TEST CONDITIONS	V <sub>CC</sub>	MIN	TYP	MAX	UNIT
V <sub>IT+</sub>	Positive-going input threshold voltage		1.8 V	0.80		1.40	V
			3 V	1.50		2.10	
V <sub>IT-</sub>	Negative-going input threshold voltage		1.8 V	0.45		1.00	V
			3 V	0.75		1.65	
V <sub>hys</sub>	Input voltage hysteresis (V <sub>IT+</sub> – V <sub>IT-</sub> )		1.8 V	0.3		0.8	V
			3 V	0.4		1.0	
R <sub>Pull</sub>	Pullup/pulldown resistor	For pullup: V <sub>IN</sub> = V <sub>SS</sub> For pulldown: V <sub>IN</sub> = V <sub>CC</sub>		20	35	50	kΩ
C <sub>I</sub>	Input capacitance	V <sub>IN</sub> = V <sub>SS</sub> or V <sub>CC</sub>			5		pF

### Schmitt-Trigger Inputs – General Purpose I/O (P1.6 and P1.7, P2.0 to P2.7, and P3.0 and P3.1)

over recommended ranges of supply voltage and operating free-air temperature (unless otherwise noted)

PARAMETER		TEST CONDITIONS	V <sub>IO</sub>	MIN	TYP	MAX	UNIT
V <sub>IT+</sub>	Positive-going input threshold voltage		1.8 V	0.80		1.40	V
			3 V	1.20		2.00	
			5 V	2.10		2.50	
V <sub>IT-</sub>	Negative-going input threshold voltage		1.8 V	0.45		0.90	V
			3 V	0.75		1.30	
			5 V	1.10		1.60	
V <sub>hys</sub>	Input voltage hysteresis (V <sub>IT+</sub> – V <sub>IT-</sub> )		1.8 V	0.27		0.45	V
			3 V	0.45		0.65	
			5 V	0.9		1.2	
R <sub>Pull</sub>	Pullup/pulldown resistor	For pullup: V <sub>IN</sub> = V <sub>SS</sub> For pulldown: V <sub>IN</sub> = V <sub>CC</sub>		20	35	50	kΩ
C <sub>I</sub>	Input capacitance	V <sub>IN</sub> = V <sub>SS</sub> or V <sub>CC</sub>			5		pF

### Inputs – Ports P1 and P2<sup>(1)</sup>

over recommended ranges of supply voltage and operating free-air temperature (unless otherwise noted)

PARAMETER	TEST CONDITIONS	V <sub>CC</sub> or V <sub>IO</sub>	MIN	MAX	UNIT
t <sub>(int)</sub>	Port P1.0 to P1.5, External trigger pulse width to set interrupt flag	1.8 V to 3.6 V	20		ns
	Port P1.6 and P1.7, and P2.0 to P2.7, External trigger pulse width to set interrupt flag	1.8 V to 5 V	25		

- (1) Some devices may contain additional ports with interrupts. See the block diagram and terminal function descriptions.  
 (2) An external signal sets the interrupt flag every time the minimum interrupt pulse width t<sub>(int)</sub> is met. It may be set by trigger signals shorter than t<sub>(int)</sub>.

### Leakage Current – General Purpose I/O

over recommended ranges of supply voltage and operating free-air temperature (unless otherwise noted)

PARAMETER		TEST CONDITIONS	V <sub>CC</sub>	MIN	TYP	MAX	UNIT
I <sub>lkg(Px.y)</sub>	Port P1.0 to P1.5, P3.0 to P3.7, PJ.0 to PJ.6	(1) (2)	1.8 V to 3.6 V	±1		±50	nA
	Port P1.6 and P1.7, P2.0 to P2.7		1.8 V to 5 V	±1		±50	

- (1) The leakage current is measured with V<sub>SS</sub> or V<sub>CC</sub> applied to the corresponding pin(s), unless otherwise noted.  
 (2) The leakage of the digital port pins is measured individually. The port pin is selected for input and the pullup/pulldown resistor is disabled.

### Outputs – Ports P1 to P3, PJ (Full Drive Strength, P1.0 to P1.5, P3.2 to P3.7, PJ.0 to PJ.6)

over recommended ranges of supply voltage and operating free-air temperature (unless otherwise noted)

PARAMETER		TEST CONDITIONS	V <sub>CC</sub>	MIN	MAX	UNIT
V <sub>OH</sub>	High-level output voltage	I <sub>(OHmax)</sub> = –3 mA <sup>(1)</sup>	1.8 V	V <sub>CC</sub> – 0.25	V <sub>CC</sub>	V
		I <sub>(OHmax)</sub> = –10 mA <sup>(2)</sup>		V <sub>CC</sub> – 0.60	V <sub>CC</sub>	
		I <sub>(OHmax)</sub> = –5 mA <sup>(1)</sup>	3 V	V <sub>CC</sub> – 0.25	V <sub>CC</sub>	
		I <sub>(OHmax)</sub> = –15 mA <sup>(2)</sup>		V <sub>CC</sub> – 0.60	V <sub>CC</sub>	
V <sub>OL</sub>	Low-level output voltage	I <sub>(OLmax)</sub> = 3 mA <sup>(1)</sup>	1.8 V	V <sub>SS</sub>	V <sub>SS</sub> + 0.25	V
		I <sub>(OLmax)</sub> = 10 mA <sup>(2)</sup>		V <sub>SS</sub>	V <sub>SS</sub> + 0.60	
		I <sub>(OLmax)</sub> = 5 mA <sup>(1)</sup>	3 V	V <sub>SS</sub>	V <sub>SS</sub> + 0.25	
		I <sub>(OLmax)</sub> = 15 mA <sup>(2)</sup>		V <sub>SS</sub>	V <sub>SS</sub> + 0.60	

- (1) The maximum total current, I<sub>(OHmax)</sub> and I<sub>(OLmax)</sub>, for all outputs combined should not exceed ±48 mA to hold the maximum voltage drop specified.
- (2) The maximum total current, I<sub>(OHmax)</sub> and I<sub>(OLmax)</sub>, for all outputs combined should not exceed ±100 mA to hold the maximum voltage drop specified.

### Outputs – Ports P1 to P3 (Full Drive Strength, P1.6 and P1.7, P2.0 to P2.7, P3.0 and P3.1)

over recommended ranges of supply voltage and operating free-air temperature (unless otherwise noted)

PARAMETER		TEST CONDITIONS	V <sub>IO</sub>	MIN	MAX	UNIT
V <sub>OH5</sub>	High-level output voltage	I <sub>(OH5max)</sub> = –3 mA <sup>(1)</sup>	1.8 V	V <sub>IO</sub> – 0.25	V <sub>CC</sub>	V
		I <sub>(OH5max)</sub> = –10 mA <sup>(2)</sup>		V <sub>IO</sub> – 0.60	V <sub>CC</sub>	
		I <sub>(OH5max)</sub> = –5 mA <sup>(1)</sup>	3 V	V <sub>IO</sub> – 0.25	V <sub>CC</sub>	
		I <sub>(OH5max)</sub> = –15 mA <sup>(2)</sup>		V <sub>IO</sub> – 0.60	V <sub>CC</sub>	
		I <sub>(OH5max)</sub> = –7 mA <sup>(1)</sup>	5 V	V <sub>IO</sub> – 0.25	V <sub>IO</sub>	
		I <sub>(OH5max)</sub> = –20 mA <sup>(2)</sup>		V <sub>IO</sub> – 0.60	V <sub>IO</sub>	
V <sub>OL5</sub>	Low-level output voltage	I <sub>(OL5max)</sub> = 3 mA <sup>(1)</sup>	1.8 V	V <sub>SS</sub>	V <sub>SS</sub> + 0.25	V
		I <sub>(OL5max)</sub> = 10 mA <sup>(2)</sup>		V <sub>SS</sub>	V <sub>SS</sub> + 0.60	
		I <sub>(OL5max)</sub> = 5 mA <sup>(1)</sup>	3 V	V <sub>SS</sub>	V <sub>SS</sub> + 0.25	
		I <sub>(OL5max)</sub> = 15 mA <sup>(2)</sup>		V <sub>SS</sub>	V <sub>SS</sub> + 0.60	
		I <sub>(OL5max)</sub> = 7 mA <sup>(1)</sup>	5 V	V <sub>SS</sub>	V <sub>SS</sub> + 0.25	
		I <sub>(OL5max)</sub> = 20 mA <sup>(2)</sup>		V <sub>SS</sub>	V <sub>SS</sub> + 0.60	

- (1) The maximum total current, I<sub>(OH5max)</sub> and I<sub>(OL5max)</sub>, for all outputs combined should not exceed ±48 mA to hold the maximum voltage drop specified.
- (2) The maximum total current, I<sub>(OH5max)</sub> and I<sub>(OL5max)</sub>, for all outputs combined should not exceed ±200 mA to hold the maximum voltage drop specified.

### Outputs – Ports P1 to P3, PJ (Reduced Drive Strength, P1.0 to P1.5, P3.2 to P3.7, PJ.0 to PJ.6)

 over recommended ranges of supply voltage and operating free-air temperature (unless otherwise noted)<sup>(1)</sup>

PARAMETER		TEST CONDITIONS	V <sub>CC</sub>	MIN	MAX	UNIT
V <sub>OH</sub>	High-level output voltage	I <sub>(OHmax)</sub> = –1 mA <sup>(2)</sup>	1.8 V	V <sub>CC</sub> – 0.25	V <sub>CC</sub>	V
		I <sub>(OHmax)</sub> = –3 mA <sup>(3)</sup>		V <sub>CC</sub> – 0.60	V <sub>CC</sub>	
		I <sub>(OHmax)</sub> = –2 mA <sup>(2)</sup>	3 V	V <sub>CC</sub> – 0.25	V <sub>CC</sub>	
		I <sub>(OHmax)</sub> = –6 mA <sup>(3)</sup>		V <sub>CC</sub> – 0.60	V <sub>CC</sub>	
V <sub>OL</sub>	Low-level output voltage	I <sub>(OLmax)</sub> = 1 mA <sup>(2)</sup>	1.8 V	V <sub>SS</sub>	V <sub>SS</sub> + 0.25	V
		I <sub>(OLmax)</sub> = 3 mA <sup>(3)</sup>		V <sub>SS</sub>	V <sub>SS</sub> + 0.60	
		I <sub>(OLmax)</sub> = 2 mA <sup>(2)</sup>	3 V	V <sub>SS</sub>	V <sub>SS</sub> + 0.25	
		I <sub>(OLmax)</sub> = 6 mA <sup>(3)</sup>		V <sub>SS</sub>	V <sub>SS</sub> + 0.60	

- (1) Selecting reduced drive strength may reduce EMI.
- (2) The maximum total current, I<sub>(OHmax)</sub> and I<sub>(OLmax)</sub>, for all outputs combined, should not exceed ±48 mA to hold the maximum voltage drop specified.
- (3) The maximum total current, I<sub>(OHmax)</sub> and I<sub>(OLmax)</sub>, for all outputs combined, should not exceed ±100 mA to hold the maximum voltage drop specified.

### Outputs – Ports P1 to P3 (Reduced Drive Strength, P1.6 and P1.7, P2.0 to P2.7, P3.0 and P3.1)

over recommended ranges of supply voltage and operating free-air temperature (unless otherwise noted)<sup>(1)</sup>

PARAMETER	TEST CONDITIONS	V <sub>IO</sub>	MIN	MAX	UNIT
V <sub>OH5</sub> High-level output voltage	I <sub>(OH5max)</sub> = -1 mA <sup>(2)</sup>	1.8 V	V <sub>IO</sub> - 0.25	V <sub>CC</sub>	V
	I <sub>(OH5max)</sub> = -3 mA <sup>(3)</sup>		V <sub>IO</sub> - 0.60	V <sub>CC</sub>	
	I <sub>(OH5max)</sub> = -2 mA <sup>(2)</sup>	3 V	V <sub>IO</sub> - 0.25	V <sub>CC</sub>	
	I <sub>(OH5max)</sub> = -6 mA <sup>(3)</sup>		V <sub>IO</sub> - 0.60	V <sub>CC</sub>	
	I <sub>(OH5max)</sub> = -4 mA <sup>(2)</sup>	5.0 V	V <sub>IO</sub> - 0.25	V <sub>IO</sub>	
	I <sub>(OL5max)</sub> = -12 mA <sup>(3)</sup>		V <sub>IO</sub> - 0.60	V <sub>IO</sub>	
V <sub>OL5</sub> Low-level output voltage	I <sub>(OL5max)</sub> = 1 mA <sup>(2)</sup>	1.8 V	V <sub>SS</sub>	V <sub>SS</sub> + 0.25	V
	I <sub>(OL5max)</sub> = 3 mA <sup>(3)</sup>		V <sub>SS</sub>	V <sub>SS</sub> + 0.60	
	I <sub>(OL5max)</sub> = 2 mA <sup>(2)</sup>	3 V	V <sub>SS</sub>	V <sub>SS</sub> + 0.25	
	I <sub>(OL5max)</sub> = 6 mA <sup>(3)</sup>		V <sub>SS</sub>	V <sub>SS</sub> + 0.60	
	I <sub>(OH5max)</sub> = 4 mA <sup>(2)</sup>	5.0 V	V <sub>SS</sub>	V <sub>SS</sub> + 0.25	
	I <sub>(OL5max)</sub> = 12 mA <sup>(3)</sup>		V <sub>SS</sub>	V <sub>SS</sub> + 0.60	

- (1) Selecting reduced drive strength may reduce EMI.
- (2) The maximum total current, I<sub>(OH5max)</sub> and I<sub>(OL5max)</sub>, for all outputs combined, should not exceed ±48 mA to hold the maximum voltage drop specified.
- (3) The maximum total current, I<sub>(OH5max)</sub> and I<sub>(OL5max)</sub>, for all outputs combined, should not exceed ±200 mA to hold the maximum voltage drop specified.

### Output Frequency – Ports P1.0 to P1.5, P3.2 to P3.7, PJ.0 to PJ.6

over recommended ranges of supply voltage and operating free-air temperature (unless otherwise noted)

PARAMETER	TEST CONDITIONS	MIN	MAX	UNIT
f <sub>Px,y</sub> Port output frequency (with load)	PJ.0/SMCLK C <sub>L</sub> = 20 pF, R <sub>L</sub> = 1 kΩ <sup>(1) (2)</sup>	V <sub>CC</sub> = 1.8 V PMMCOREVx = 0	16	MHz
		V <sub>CC</sub> = 3 V PMMCOREVx = 3	25	
f <sub>Port_CLK</sub> Clock output frequency	PJ.3/ACLK PJ.0/SMCLK PJ.1/MCLK C <sub>L</sub> = 20 pF <sup>(2)</sup>	V <sub>CC</sub> = 1.8 V PMMCOREVx = 0	16	MHz
		V <sub>CC</sub> = 3 V PMMCOREVx = 3	25	

- (1) A resistive divider with 2 × 0.5 kΩ between V<sub>CC</sub> and V<sub>SS</sub> is used as load. The output is connected to the center tap of the divider.
- (2) The output voltage reaches at least 10% and 90% V<sub>CC</sub> at the specified toggle frequency.

### Output Frequency – Ports P1.6 and P1.7, P2.0 to P2.7, P3.0 and P3.1

over recommended ranges of supply voltage and operating free-air temperature (unless otherwise noted)

PARAMETER	TEST CONDITIONS	MIN	MAX	UNIT
f <sub>Px,y</sub> Port output frequency (with load)	P1.6 port mapper SMCLK from P3.4 C <sub>L</sub> = 20 pF, R <sub>L</sub> = 1 kΩ <sup>(1) (2)</sup>	V <sub>CC</sub> = 1.8 V, V <sub>IO</sub> = 1.8 V PMMCOREVx = 0	16	MHz
		V <sub>CC</sub> = 3 V, V <sub>IO</sub> = 3 V PMMCOREVx = 3	25	
		V <sub>CC</sub> = 3 V, V <sub>IO</sub> = 5 V PMMCOREVx = 3	25	
f <sub>Port_CLK</sub> Clock output frequency	P1.6 port mapper SMCLK from P3.4 C <sub>L</sub> = 20 pF <sup>(2)</sup>	V <sub>CC</sub> = 1.8 V, V <sub>IO</sub> = 1.8 V PMMCOREVx = 0	16	MHz
		V <sub>CC</sub> = 3 V, V <sub>IO</sub> = 3 V PMMCOREVx = 3	25	
		V <sub>CC</sub> = 3 V, V <sub>IO</sub> = 5 V PMMCOREVx = 3	25	

- (1) A resistive divider with 2 × 0.5 kΩ between V<sub>CC</sub> and V<sub>SS</sub> is used as load. The output is connected to the center tap of the divider.
- (2) The output voltage reaches at least 10% and 90% V<sub>CC</sub> at the specified toggle frequency.

**Typical Characteristics – Outputs, Reduced Drive Strength (PxDS.y = 0), Ports P1.0 to P1.5, P3.2 to P3.7, PJ.0 to PJ.6**

over recommended ranges of supply voltage and operating free-air temperature (unless otherwise noted)

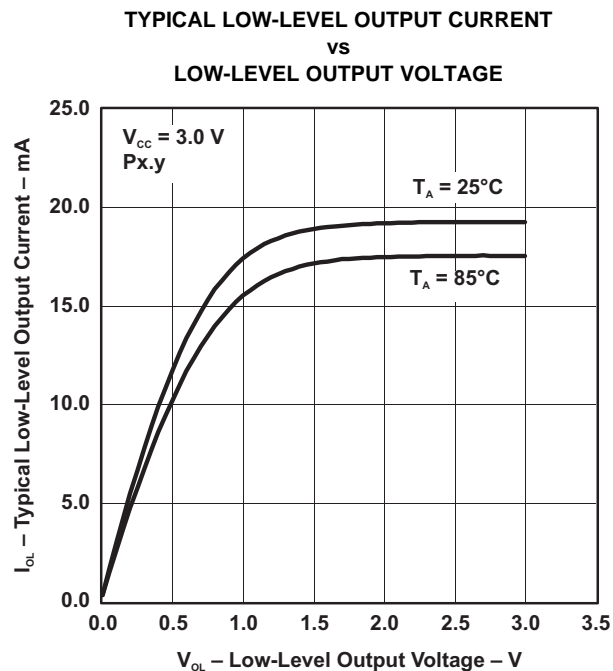

Figure 2.

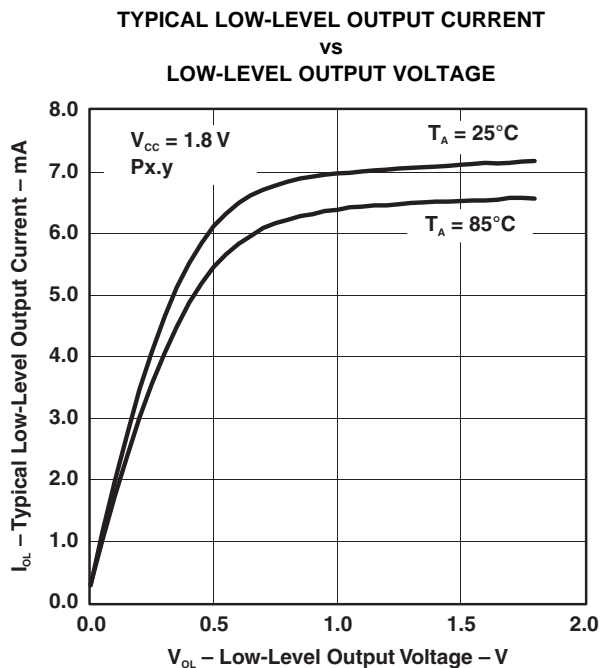

Figure 3.

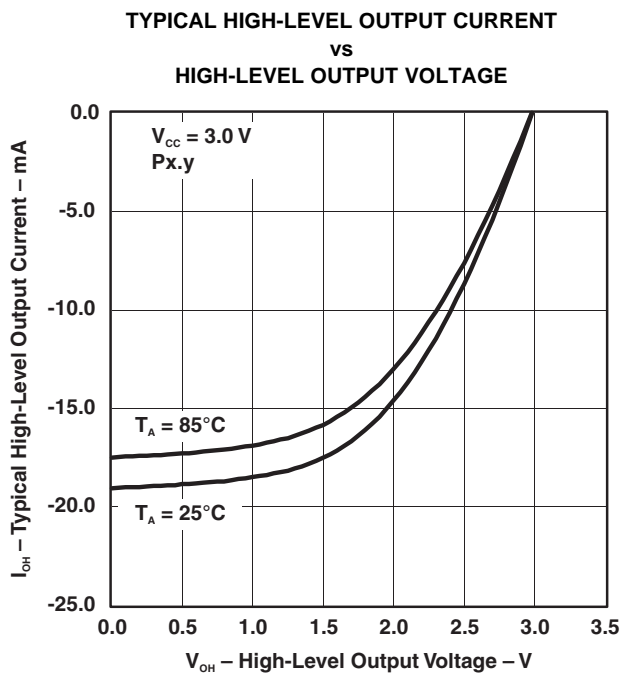

Figure 4.

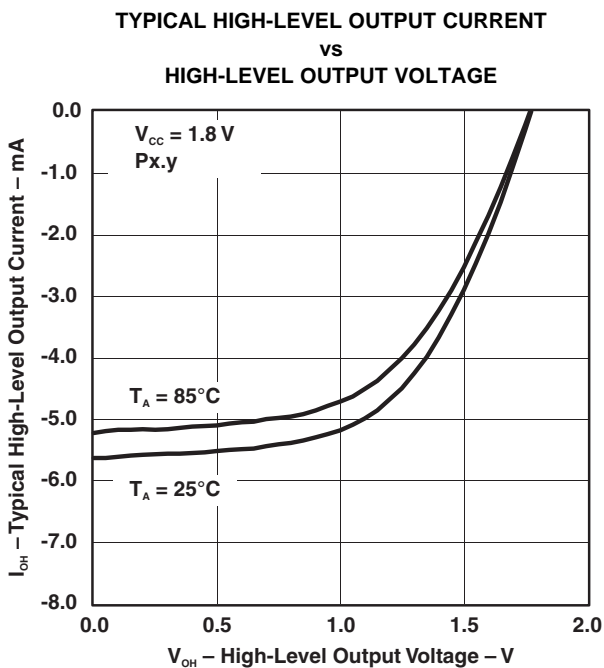

Figure 5.

**Typical Characteristics – Outputs, Full Drive Strength (PxDS.y = 1), Ports P1.0 to P1.5, P3.2 to P3.7, PJ.0 to PJ.6**

over recommended ranges of supply voltage and operating free-air temperature (unless otherwise noted)

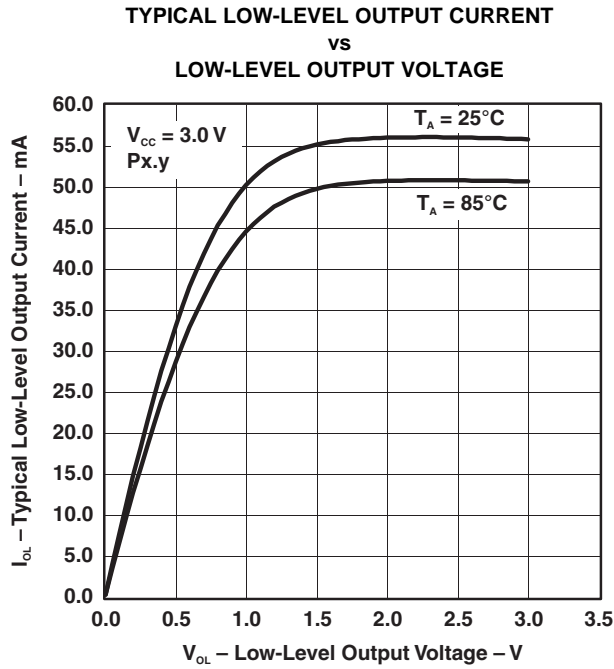

Figure 6.

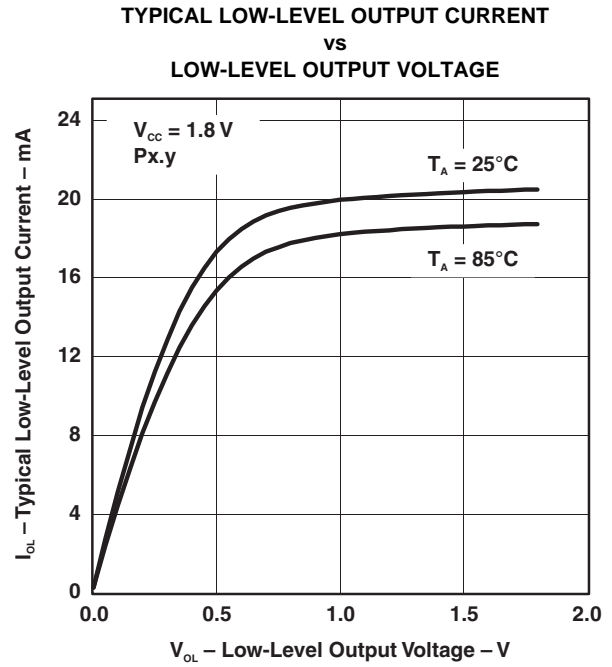

Figure 7.

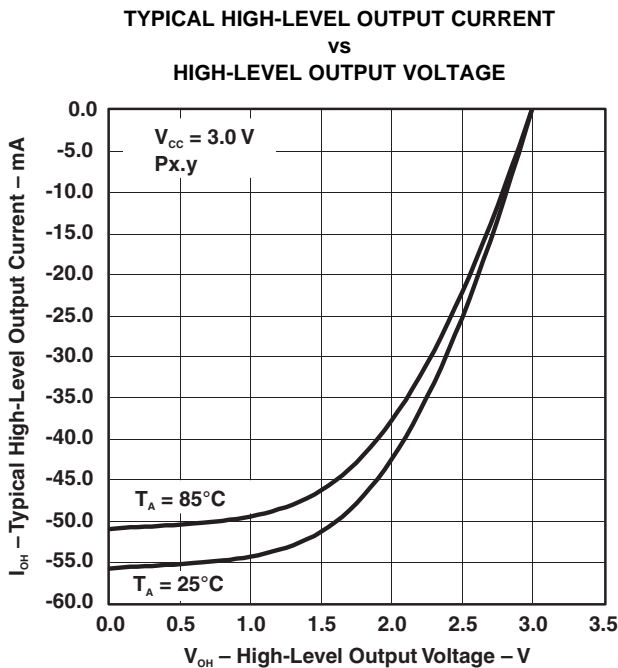

Figure 8.

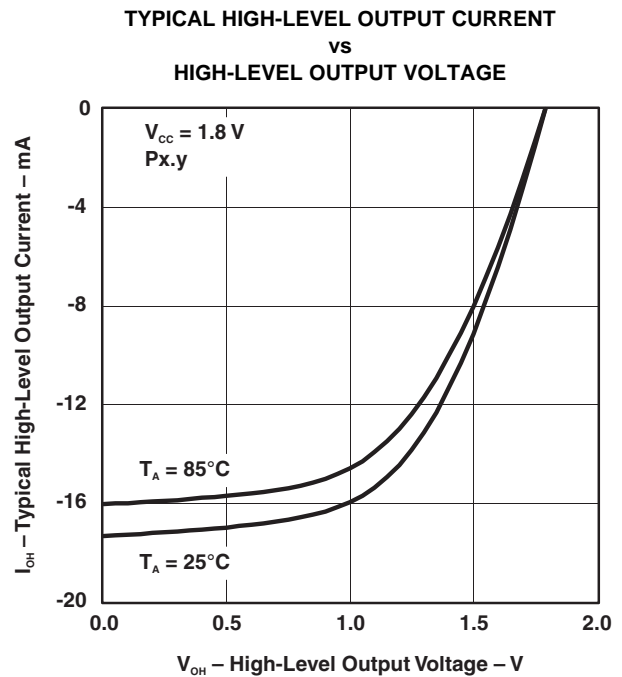
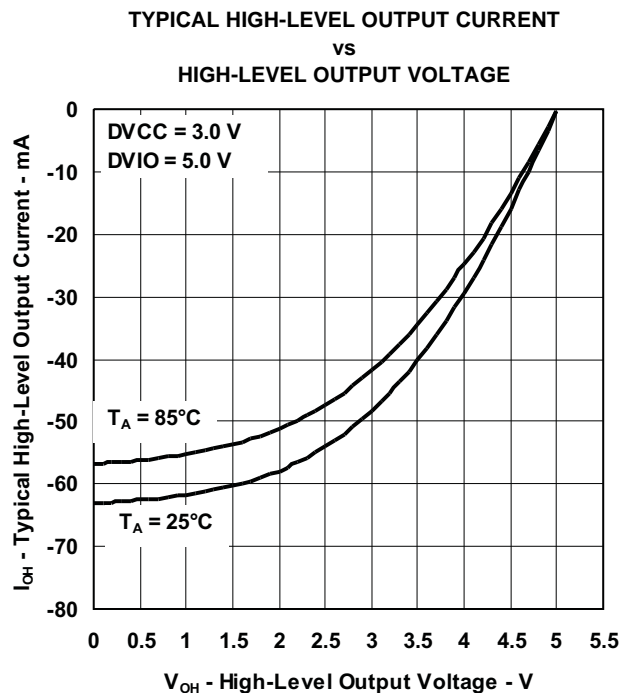
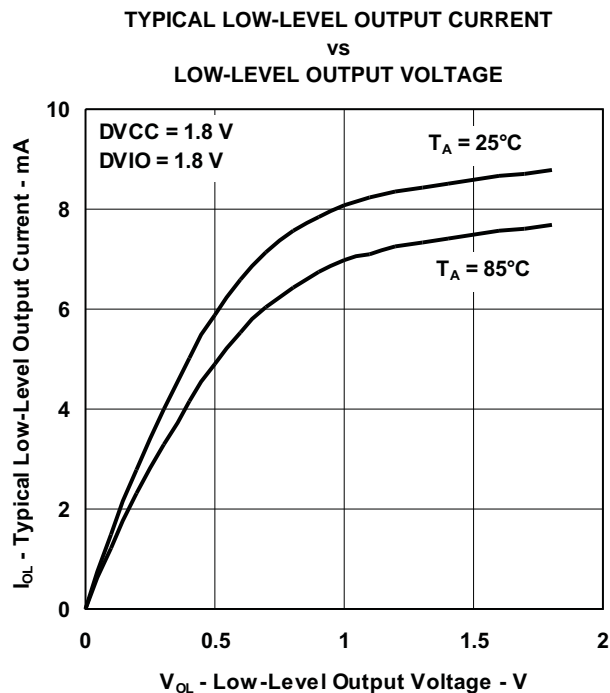
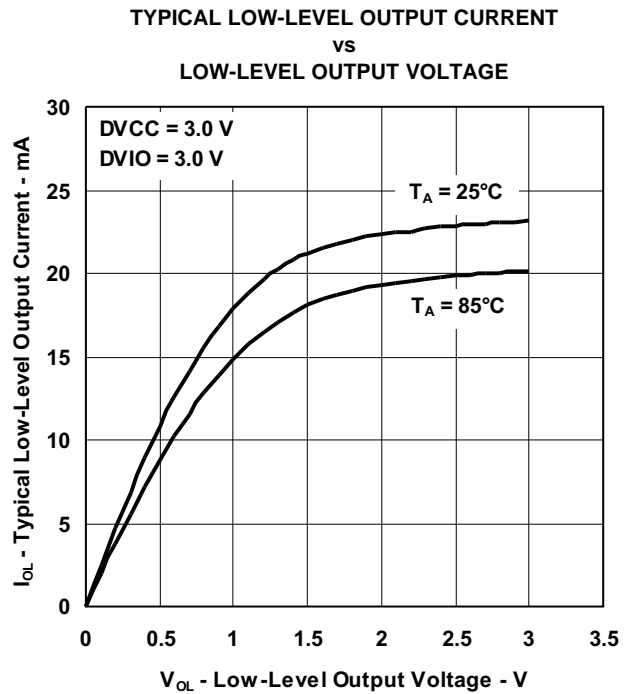
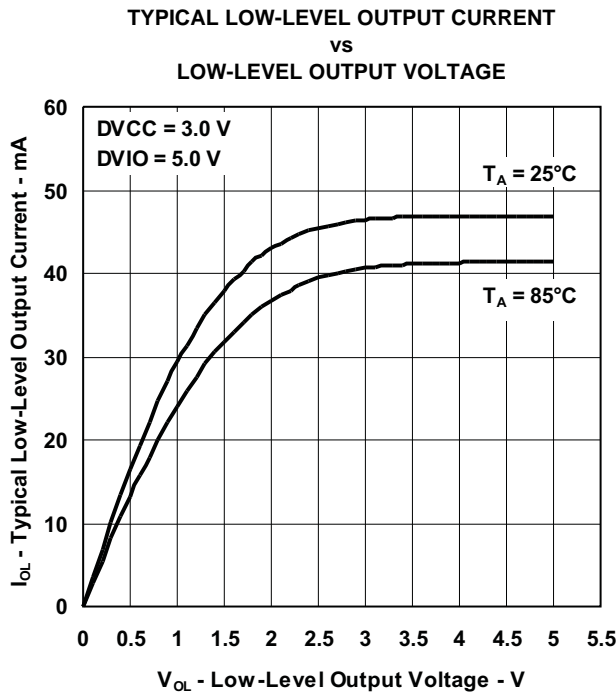

Figure 9.

**Typical Characteristics – Outputs, Reduced Drive Strength (PxDS.y = 0), Ports P1.6 and P1.7, P2.0 to P2.7, P3.0 and P3.1**

over recommended ranges of supply voltage and operating free-air temperature (unless otherwise noted)



**Typical Characteristics – Outputs, Reduced Drive Strength (PxDS.y = 0), Ports P1.6 and P1.7, P2.0 to P2.7, P3.0 and P3.1 (continued)**

over recommended ranges of supply voltage and operating free-air temperature (unless otherwise noted)

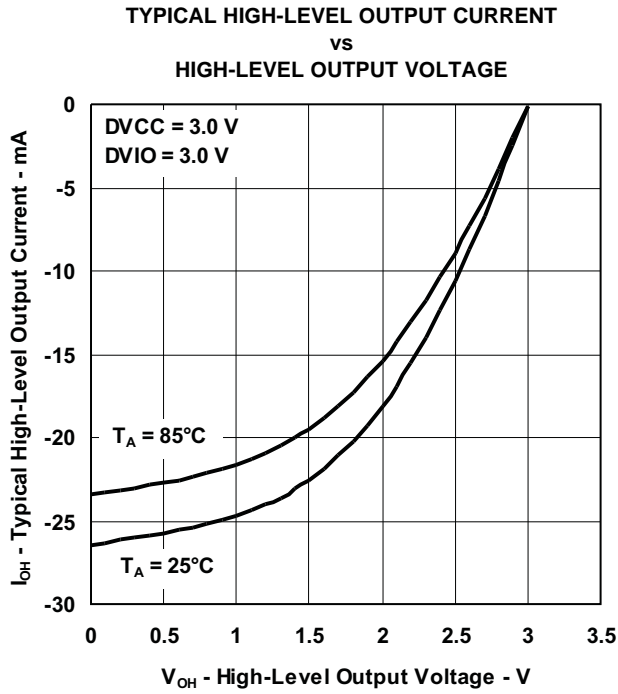

Figure 14.

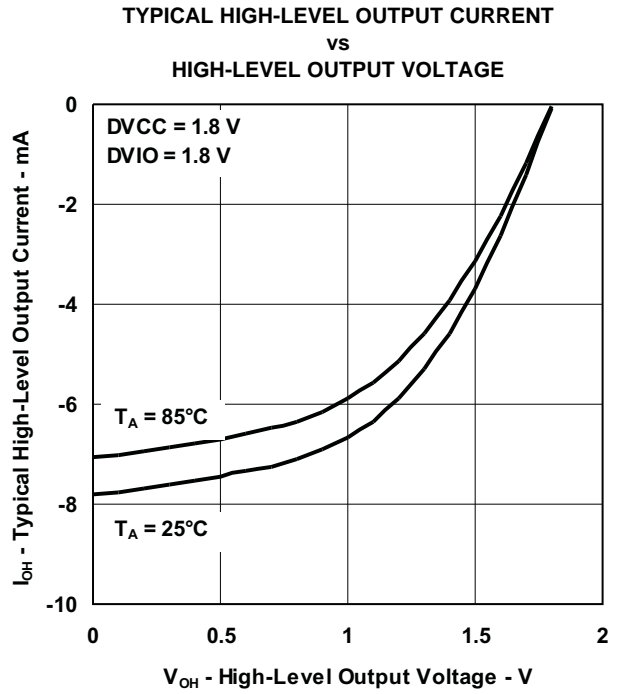

Figure 15.

**Typical Characteristics – Outputs, Full Drive Strength (PxDS.y = 1), Ports P1.6 and P1.7, P2.0 to P2.7, P3.0 and P3.1**

over recommended ranges of supply voltage and operating free-air temperature (unless otherwise noted)

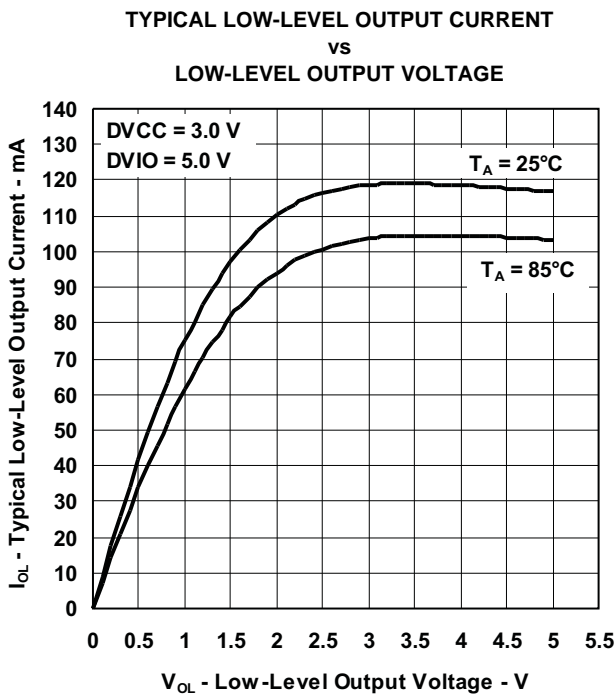

Figure 16.

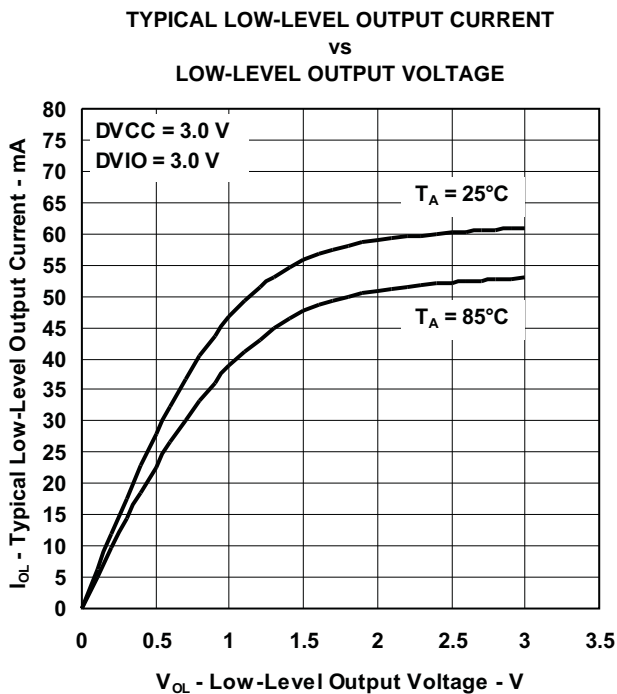

Figure 17.

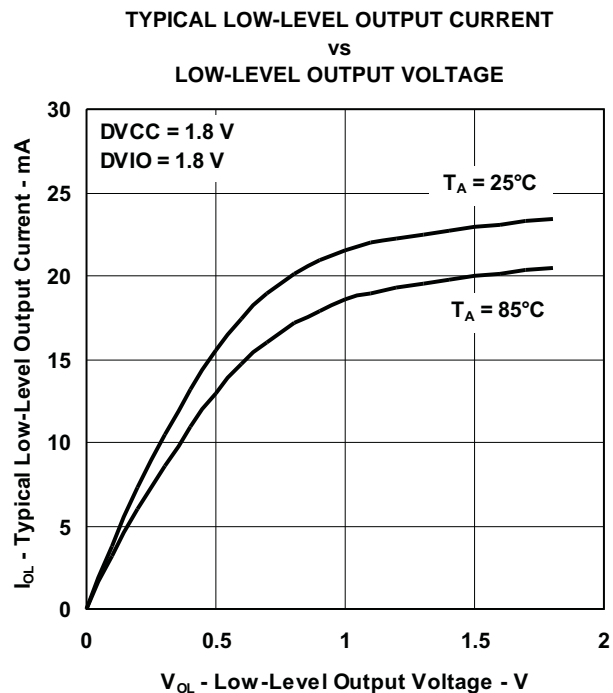

Figure 18.

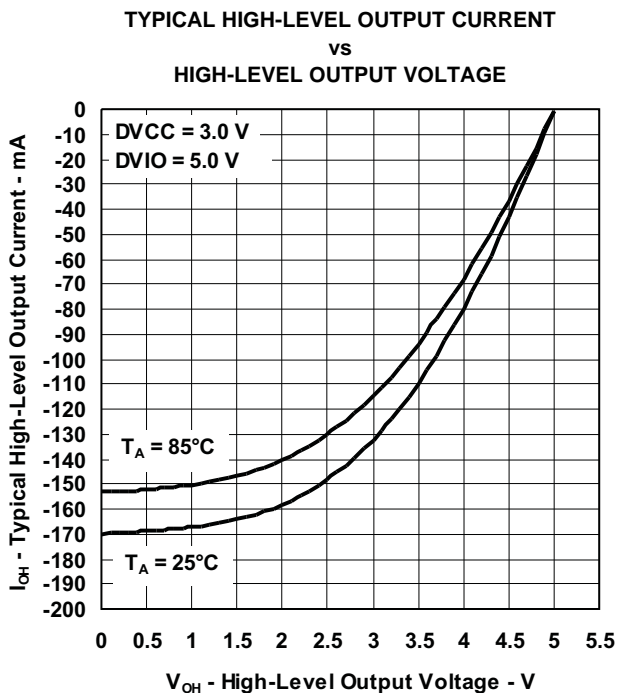
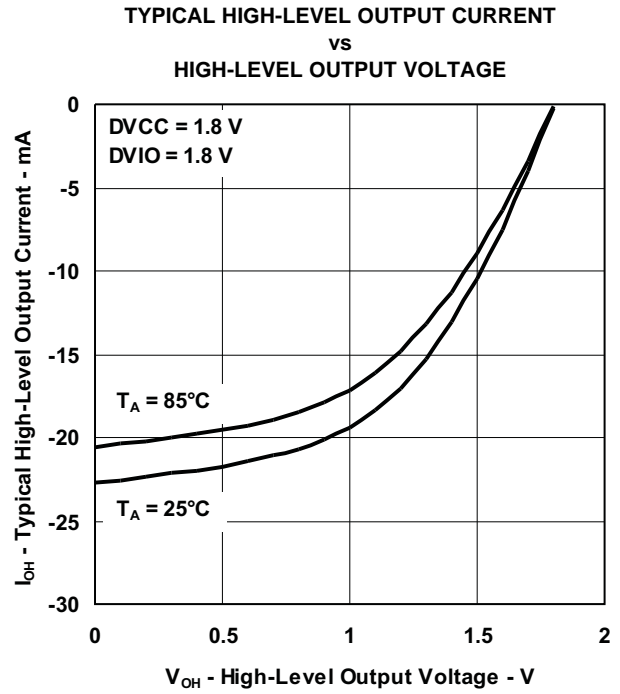
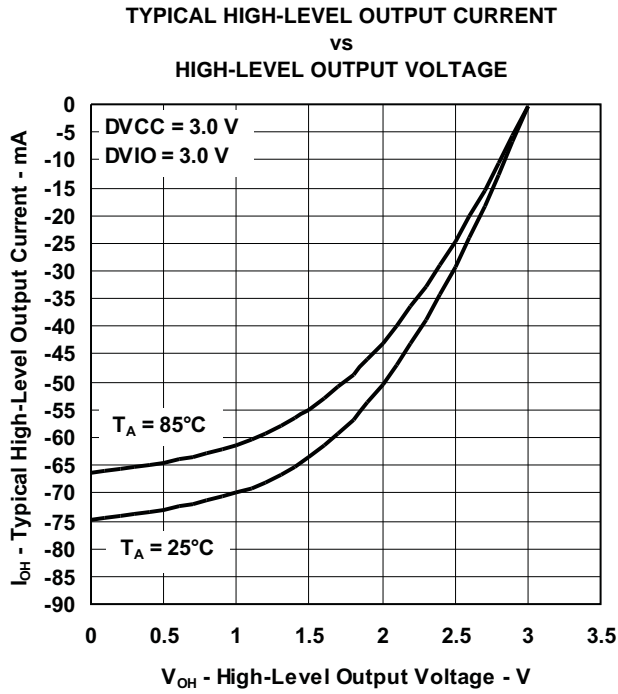

Figure 19.

**Typical Characteristics – Outputs, Full Drive Strength (PxDS.y = 1), Ports P1.6 and P1.7, P2.0 to P2.7, P3.0 and P3.1 (continued)**

over recommended ranges of supply voltage and operating free-air temperature (unless otherwise noted)



## Crystal Oscillator, XT1, Low-Frequency Mode

over recommended ranges of supply voltage and operating free-air temperature (unless otherwise noted)

PARAMETER	TEST CONDITIONS	V <sub>CC</sub>	MIN	TYP	MAX	UNIT
I <sub>DVCC,LF</sub>	f <sub>OSC</sub> = 32768 Hz, XTS = 0, XT1BYPASS = 0, XT1DRIVE <sub>x</sub> = 1, T <sub>A</sub> = 25°C	3 V	0.075			μA
	f <sub>OSC</sub> = 32768 Hz, XTS = 0, XT1BYPASS = 0, XT1DRIVE <sub>x</sub> = 2, T <sub>A</sub> = 25°C		0.170			
	f <sub>OSC</sub> = 32768 Hz, XTS = 0, XT1BYPASS = 0, XT1DRIVE <sub>x</sub> = 3, T <sub>A</sub> = 25°C		0.290			
f <sub>XT1,LF0</sub>	XT1 oscillator crystal frequency, LF mode		32768			Hz
f <sub>XT1,LF,SW</sub>	XT1 oscillator logic-level square-wave input frequency, LF mode		10	32.768	50	kHz
O <sub>A,LF</sub>	XTS = 0, XT1BYPASS = 0, XT1DRIVE <sub>x</sub> = 0, f <sub>XT1,LF</sub> = 32768 Hz, C <sub>L,eff</sub> = 6 pF		210			kΩ
	XTS = 0, XT1BYPASS = 0, XT1DRIVE <sub>x</sub> = 1, f <sub>XT1,LF</sub> = 32768 Hz, C <sub>L,eff</sub> = 12 pF		300			
C <sub>L,eff</sub>	XTS = 0, XCAP <sub>x</sub> = 0		2			pF
	XTS = 0, XCAP <sub>x</sub> = 1		5.5			
	XTS = 0, XCAP <sub>x</sub> = 2		8.5			
	XTS = 0, XCAP <sub>x</sub> = 3		12.0			
	Duty cycle, LF mode		30		70	%
f <sub>Fault,LF</sub>	Oscillator fault frequency, LF mode		10		10000	Hz
t <sub>START,LF</sub>	f <sub>OSC</sub> = 32768 Hz, XTS = 0, XT1BYPASS = 0, XT1DRIVE <sub>x</sub> = 0, T <sub>A</sub> = 25°C, C <sub>L,eff</sub> = 12 pF	3 V	1000			ms
	f <sub>OSC</sub> = 32768 Hz, XTS = 0, XT1BYPASS = 0, XT1DRIVE <sub>x</sub> = 3, T <sub>A</sub> = 25°C, C <sub>L,eff</sub> = 12 pF		500			

### Crystal Oscillator, XT1, High-Frequency Mode<sup>(1)</sup>

over recommended ranges of supply voltage and operating free-air temperature (unless otherwise noted)

PARAMETER		TEST CONDITIONS	V <sub>CC</sub>	MIN	TYP	MAX	UNIT
I <sub>DVCC,HF</sub>	Differential XT1 oscillator crystal current consumption from lowest drive setting, HF mode	f <sub>OSC</sub> = 4 MHz, XTS = 1, XOSCOFF = 0, XT1BYPASS = 0, XT1DRIVE <sub>x</sub> = 0, T <sub>A</sub> = 25°C	3 V		200		μA
		f <sub>OSC</sub> = 12 MHz, XTS = 1, XOSCOFF = 0, XT1BYPASS = 0, XT1DRIVE <sub>x</sub> = 1, T <sub>A</sub> = 25°C			260		
		f <sub>OSC</sub> = 20 MHz, XTS = 1, XOSCOFF = 0, XT1BYPASS = 0, XT1DRIVE <sub>x</sub> = 2, T <sub>A</sub> = 25°C			325		
		f <sub>OSC</sub> = 32 MHz, XTS = 1, XOSCOFF = 0, XT1BYPASS = 0, XT1DRIVE <sub>x</sub> = 3, T <sub>A</sub> = 25°C			450		
f <sub>XT1,HF0</sub>	XT1 oscillator crystal frequency, HF mode 0	XTS = 1, XT1BYPASS = 0, XT1DRIVE <sub>x</sub> = 0 <sup>(2)</sup>		4		8	MHz
f <sub>XT1,HF1</sub>	XT1 oscillator crystal frequency, HF mode 1	XTS = 1, XT1BYPASS = 0, XT1DRIVE <sub>x</sub> = 1 <sup>(2)</sup>		8		16	MHz
f <sub>XT1,HF2</sub>	XT1 oscillator crystal frequency, HF mode 2	XTS = 1, XT1BYPASS = 0, XT1DRIVE <sub>x</sub> = 2 <sup>(2)</sup>		16		24	MHz
f <sub>XT1,HF3</sub>	XT1 oscillator crystal frequency, HF mode 3	XTS = 1, XT1BYPASS = 0, XT1DRIVE <sub>x</sub> = 3 <sup>(2)</sup>		24		32	MHz
f <sub>XT1,HF,SW</sub>	XT1 oscillator logic-level square-wave input frequency, HF mode	XTS = 1, XT1BYPASS = 1 <sup>(3) (2)</sup>		0.7		32	MHz
O <sub>AHF</sub>	Oscillation allowance for HF crystals <sup>(4)</sup>	XTS = 1, XT1BYPASS = 0, XT1DRIVE <sub>x</sub> = 0, f <sub>XT1,HF</sub> = 6 MHz, C <sub>L,eff</sub> = 15 pF			450		kΩ
		XTS = 1, XT1BYPASS = 0, XT1DRIVE <sub>x</sub> = 1, f <sub>XT1,HF</sub> = 12 MHz, C <sub>L,eff</sub> = 15 pF			320		
		XTS = 1, XT1BYPASS = 0, XT1DRIVE <sub>x</sub> = 2, f <sub>XT1,HF</sub> = 20 MHz, C <sub>L,eff</sub> = 15 pF			200		
		XTS = 1, XT1BYPASS = 0, XT1DRIVE <sub>x</sub> = 3, f <sub>XT1,HF</sub> = 32 MHz, C <sub>L,eff</sub> = 15 pF			200		
t <sub>START,HF</sub>	Startup time, HF mode	f <sub>OSC</sub> = 6 MHz, XTS = 1, XT1BYPASS = 0, XT1DRIVE <sub>x</sub> = 0, T <sub>A</sub> = 25°C, C <sub>L,eff</sub> = 15 pF	3 V		0.5		ms
		f <sub>OSC</sub> = 20 MHz, XTS = 1, XT1BYPASS = 0, XT1DRIVE <sub>x</sub> = 2, T <sub>A</sub> = 25°C, C <sub>L,eff</sub> = 15 pF			0.3		

- (1) To improve EMI on the XT1 oscillator the following guidelines should be observed.
- Keep the traces between the device and the crystal as short as possible.
  - Design a good ground plane around the oscillator pins.
  - Prevent crosstalk from other clock or data lines into oscillator pins XIN and XOUT.
  - Avoid running PCB traces underneath or adjacent to the XIN and XOUT pins.
  - Use assembly materials and praxis to avoid any parasitic load on the oscillator XIN and XOUT pins.
  - If conformal coating is used, ensure that it does not induce capacitive/resistive leakage between the oscillator pins.
- (2) Maximum frequency of operation of the entire device cannot be exceeded.
- (3) When XT1BYPASS is set, the VLO, REFO, XT1 circuits are automatically powered down.
- (4) Oscillation allowance is based on a safety factor of 5 for recommended crystals.

## Crystal Oscillator, XT1, High-Frequency Mode<sup>(1)</sup> (continued)

over recommended ranges of supply voltage and operating free-air temperature (unless otherwise noted)

PARAMETER		TEST CONDITIONS	V <sub>CC</sub>	MIN	TYP	MAX	UNIT
C <sub>L,eff</sub>	Integrated effective load capacitance, HF mode <sup>(5)</sup> (6)	XTS = 1			1		pF
	Duty cycle, HF mode	XTS = 1, Measured at ACLK, f <sub>XT1,HF2</sub> = 20 MHz		40	50	60	%
f <sub>Fault,HF</sub>	Oscillator fault frequency, HF mode <sup>(7)</sup>	XTS = 1 <sup>(8)</sup>		30		300	kHz

(5) Includes parasitic bond and package capacitance (approximately 2 pF per pin).

Since the PCB adds additional capacitance, it is recommended to verify the correct load by measuring the ACLK frequency. For a correct setup, the effective load capacitance should always match the specification of the used crystal.

(6) Requires external capacitors at both terminals. Values are specified by crystal manufacturers.

(7) Frequencies below the MIN specification set the fault flag. Frequencies above the MAX specification do not set the fault flag. Frequencies in between might set the flag.

(8) Measured with logic-level input frequency but also applies to operation with crystals.

## Internal Very-Low-Power Low-Frequency Oscillator (VLO)

over recommended ranges of supply voltage and operating free-air temperature (unless otherwise noted)

PARAMETER		TEST CONDITIONS	V <sub>CC</sub>	MIN	TYP	MAX	UNIT
f <sub>VLO</sub>	VLO frequency	Measured at ACLK	1.8 V to 3.6 V	6	9.4	14	kHz
df <sub>VLO</sub> /dT	VLO frequency temperature drift	Measured at ACLK <sup>(1)</sup>	1.8 V to 3.6 V		0.5		%/°C
df <sub>VLO</sub> /dV <sub>CC</sub>	VLO frequency supply voltage drift	Measured at ACLK <sup>(2)</sup>	1.8 V to 3.6 V		4		%/V
	Duty cycle	Measured at ACLK	1.8 V to 3.6 V	40	50	60	%

(1) Calculated using the box method: (MAX(-40 to 85°C) MIN(-40 to 85°C)) / MIN(85°C (40°C)). The coefficient is negative.

(2) Calculated using the box method: (MAX(1.8 to 3.6 V) MIN(1.8 to 3.6 V)) / MIN(1.8 to 3.6 V) / (3.6 V 1.8 V). The coefficient is positive.

## Internal Reference, Low-Frequency Oscillator (REFO)

over recommended ranges of supply voltage and operating free-air temperature (unless otherwise noted)

PARAMETER		TEST CONDITIONS	V <sub>CC</sub>	MIN	TYP	MAX	UNIT
I <sub>REFO</sub>	REFO oscillator current consumption	T <sub>A</sub> = 25°C	1.8 V to 3.6 V		3		μA
f <sub>REFO</sub>	REFO frequency calibrated	Measured at ACLK	1.8 V to 3.6 V		32768		Hz
	REFO absolute tolerance calibrated	Full temperature range	1.8 V to 3.6 V			±3.5	%
		T <sub>A</sub> = 25°C	3 V			±1.5	%
df <sub>REFO</sub> /dT	REFO frequency temperature drift	Measured at ACLK <sup>(1)</sup>	1.8 V to 3.6 V		0.01		%/°C
df <sub>REFO</sub> /dV <sub>CC</sub>	REFO frequency supply voltage drift	Measured at ACLK <sup>(2)</sup>	1.8 V to 3.6 V		1.0		%/V
	Duty cycle	Measured at ACLK	1.8 V to 3.6 V	40	50	60	%
t <sub>START</sub>	REFO startup time	40%/60% duty cycle	1.8 V to 3.6 V		25		μA

(1) Calculated using the box method: (MAX(-40 to 85°C) MIN(-40 to 85°C)) / MIN(85°C (40°C))

(2) Calculated using the box method: (MAX(1.8 to 3.6 V) MIN(1.8 to 3.6 V)) / MIN(1.8 to 3.6 V) / (3.6 V 1.8 V)

## DCO Frequency

over recommended ranges of supply voltage and operating free-air temperature (unless otherwise noted)

PARAMETER	TEST CONDITIONS	MIN	TYP	MAX	UNIT	
$f_{\text{DCO}(0,0)}$	DCO frequency (0, 0)	DCORSELx = 0, DCOx = 0, MODx = 0	0.07	0.20	MHz	
$f_{\text{DCO}(0,31)}$	DCO frequency (0, 31)	DCORSELx = 0, DCOx = 31, MODx = 0	0.70	1.70	MHz	
$f_{\text{DCO}(1,0)}$	DCO frequency (1, 0)	DCORSELx = 1, DCOx = 0, MODx = 0	0.15	0.38	MHz	
$f_{\text{DCO}(1,31)}$	DCO frequency (1, 31)	DCORSELx = 1, DCOx = 31, MODx = 0	1.47	3.45	MHz	
$f_{\text{DCO}(2,0)}$	DCO frequency (2, 0)	DCORSELx = 2, DCOx = 0, MODx = 0	0.32	0.75	MHz	
$f_{\text{DCO}(2,31)}$	DCO frequency (2, 31)	DCORSELx = 2, DCOx = 31, MODx = 0	3.17	7.38	MHz	
$f_{\text{DCO}(3,0)}$	DCO frequency (3, 0)	DCORSELx = 3, DCOx = 0, MODx = 0	0.64	1.51	MHz	
$f_{\text{DCO}(3,31)}$	DCO frequency (3, 31)	DCORSELx = 3, DCOx = 31, MODx = 0	6.07	14.0	MHz	
$f_{\text{DCO}(4,0)}$	DCO frequency (4, 0)	DCORSELx = 4, DCOx = 0, MODx = 0	1.3	3.2	MHz	
$f_{\text{DCO}(4,31)}$	DCO frequency (4, 31)	DCORSELx = 4, DCOx = 31, MODx = 0	12.3	28.2	MHz	
$f_{\text{DCO}(5,0)}$	DCO frequency (5, 0)	DCORSELx = 5, DCOx = 0, MODx = 0	2.5	6.0	MHz	
$f_{\text{DCO}(5,31)}$	DCO frequency (5, 31)	DCORSELx = 5, DCOx = 31, MODx = 0	23.7	54.1	MHz	
$f_{\text{DCO}(6,0)}$	DCO frequency (6, 0)	DCORSELx = 6, DCOx = 0, MODx = 0	4.6	10.7	MHz	
$f_{\text{DCO}(6,31)}$	DCO frequency (6, 31)	DCORSELx = 6, DCOx = 31, MODx = 0	39.0	88.0	MHz	
$f_{\text{DCO}(7,0)}$	DCO frequency (7, 0)	DCORSELx = 7, DCOx = 0, MODx = 0	8.5	19.6	MHz	
$f_{\text{DCO}(7,31)}$	DCO frequency (7, 31)	DCORSELx = 7, DCOx = 31, MODx = 0	60	135	MHz	
$S_{\text{DCORSEL}}$	Frequency step between range DCORSEL and DCORSEL + 1	$S_{\text{RSEL}} = f_{\text{DCO}(\text{DCORSEL}+1, \text{DCO})} / f_{\text{DCO}(\text{DCORSEL}, \text{DCO})}$	1.2	2.4	ratio	
$S_{\text{DCO}}$	Frequency step between tap DCO and DCO + 1	$S_{\text{DCO}} = f_{\text{DCO}(\text{DCORSEL}, \text{DCO}+1)} / f_{\text{DCO}(\text{DCORSEL}, \text{DCO})}$	1.02	1.12	ratio	
	Duty cycle	Measured at SMCLK	40	50	60	%
$df_{\text{DCO}}/dT$	DCO frequency temperature drift	$f_{\text{DCO}} = 1 \text{ MHz}$ , $V_{\text{CORE}} = 1.2 \text{ V}/2.0 \text{ V}$		0.1		%/°C
$df_{\text{DCO}}/dV_{\text{CORE}}$	DCO frequency voltage drift	$f_{\text{DCO}} = 1 \text{ MHz}$		1.9		%/V

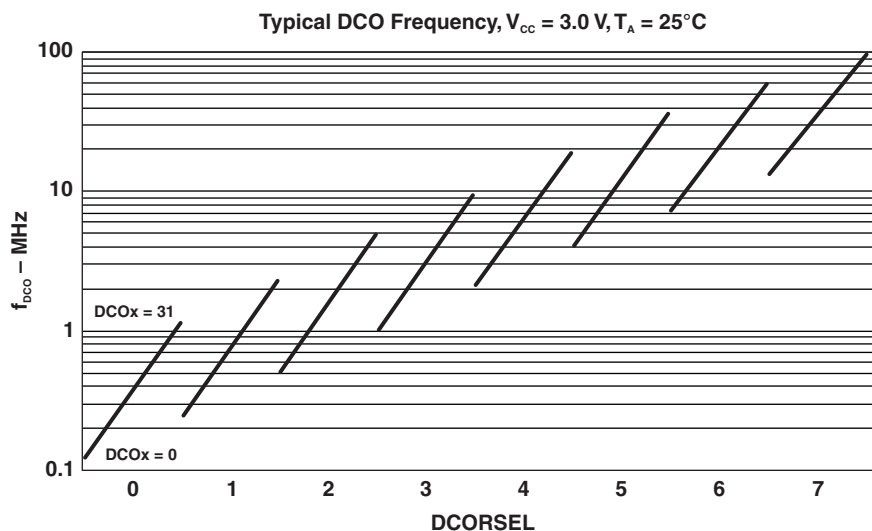

Figure 22. Typical DCO frequency

## PMM, Brown-Out Reset (BOR)

over recommended ranges of supply voltage and operating free-air temperature (unless otherwise noted)

PARAMETER		TEST CONDITIONS	MIN	TYP	MAX	UNIT
$V_{(DVCC\_BOR\_IT-)}$	BOR <sub>H</sub> on voltage, DV <sub>CC</sub> falling level	$dDV_{CC}/dt < 3 \text{ V/s}$			1.45	V
$V_{(DVCC\_BOR\_IT+)}$	BOR <sub>H</sub> off voltage, DV <sub>CC</sub> rising level	$dDV_{CC}/dt < 3 \text{ V/s}$	0.80	1.30	1.50	V
$V_{(DVCC\_BOR\_hys)}$	BOR <sub>H</sub> hysteresis		40		275	mV
$V_{(V_{CORE\_BOR\_IT-})}$	BOR <sub>L</sub> on voltage, V <sub>CORE</sub> falling level	DV <sub>CC</sub> = 1.8 V to 3.6 V	0.69		0.87	V
$V_{(V_{CORE\_BOR\_IT+})}$	BOR <sub>L</sub> off voltage, V <sub>CORE</sub> rising level	DV <sub>CC</sub> = 1.8 V to 3.6 V	0.83		1.05	V
$V_{(V_{CORE\_BOR\_hys})}$	BOR <sub>L</sub> hysteresis		60		200	mV
$t_{dBOR}$	BOR <sub>L</sub> reset release time				2000	μs
$t_{RESET}$	Pulse length required at RST/NMI pin to accept a reset		2			μs

## PMM, Core Voltage

over recommended ranges of supply voltage and operating free-air temperature (unless otherwise noted)

PARAMETER		TEST CONDITIONS	MIN	TYP	MAX	UNIT
$V_{CORE3(AM)}$	Core voltage, active mode, PMMCOREV = 3	$2.4 \text{ V} \leq DV_{CC} \leq 3.6 \text{ V}, 0 \text{ mA} \leq I(V_{CORE}) \leq 25 \text{ mA}$		1.90		V
$V_{CORE2(AM)}$	Core voltage, active mode, PMMCOREV = 2	$2.2 \text{ V} \leq DV_{CC} \leq 3.6 \text{ V}, 0 \text{ mA} \leq I(V_{CORE}) \leq 21 \text{ mA}$		1.80		V
$V_{CORE1(AM)}$	Core voltage, active mode, PMMCOREV = 1	$2.0 \text{ V} \leq DV_{CC} \leq 3.6 \text{ V}, 0 \text{ mA} \leq I(V_{CORE}) \leq 17 \text{ mA}$		1.60		V
$V_{CORE0(AM)}$	Core voltage, active mode, PMMCOREV = 0	$1.8 \text{ V} \leq DV_{CC} \leq 3.6 \text{ V}, 0 \text{ mA} \leq I(V_{CORE}) \leq 13 \text{ mA}$		1.40		V
$V_{CORE3(LPM)}$	Core voltage, active mode, PMMCOREV = 3	$2.4 \text{ V} \leq DV_{CC} \leq 3.6 \text{ V}, 0 \text{ mA} \leq I(V_{CORE}) \leq 30 \text{ μA}$		1.94		V
$V_{CORE2(LPM)}$	Core voltage, low-current mode, PMMCOREV = 2	$2.2 \text{ V} \leq DV_{CC} \leq 3.6 \text{ V}, 0 \text{ μA} \leq I(V_{CORE}) \leq 30 \text{ μA}$		1.84		V
$V_{CORE1(LPM)}$	Core voltage, low-current mode, PMMCOREV = 1	$2.0 \text{ V} \leq DV_{CC} \leq 3.6 \text{ V}, 0 \text{ μA} \leq I(V_{CORE}) \leq 30 \text{ μA}$		1.64		V
$V_{CORE0(LPM)}$	Core voltage, low-current mode, PMMCOREV = 0	$1.8 \text{ V} \leq DV_{CC} \leq 3.6 \text{ V}, 0 \text{ μA} \leq I(V_{CORE}) \leq 30 \text{ μA}$		1.44		V

### PMM, SVS High Side

over recommended ranges of supply voltage and operating free-air temperature (unless otherwise noted)

PARAMETER		TEST CONDITIONS	MIN	TYP	MAX	UNIT
$I_{(SVSH)}$	SVS current consumption	SVSHE = 0, DV <sub>CC</sub> = 3.6 V		0		nA
		SVSHE = 1, DV <sub>CC</sub> = 3.6 V, SVSHFP = 0		200		nA
		SVSHE = 1, DV <sub>CC</sub> = 3.6 V, SVSHFP = 1		2		μA
$V_{(SVSH\_IT-)}$	SVS <sub>H</sub> on voltage level	SVSHE = 1, SVSHRVL = 0	1.59	1.64	1.69	V
		SVSHE = 1, SVSHRVL = 1	1.79	1.84	1.91	
		SVSHE = 1, SVSHRVL = 2	1.98	2.04	2.11	
		SVSHE = 1, SVSHRVL = 3	2.10	2.16	2.23	
$V_{(SVSH\_IT+)}$	SVS <sub>H</sub> off voltage level	SVSHE = 1, SVSMHRRL = 0	1.62	1.74	1.81	V
		SVSHE = 1, SVSMHRRL = 1	1.88	1.94	2.01	
		SVSHE = 1, SVSMHRRL = 2	2.07	2.14	2.21	
		SVSHE = 1, SVSMHRRL = 3	2.20	2.26	2.33	
		SVSHE = 1, SVSMHRRL = 4	2.32	2.40	2.48	
		SVSHE = 1, SVSMHRRL = 5	2.56	2.70	2.84	
		SVSHE = 1, SVSMHRRL = 6	2.85	3.00	3.15	
		SVSHE = 1, SVSMHRRL = 7	2.85	3.00	3.15	
$t_{pd(SVSH)}$	SVS <sub>H</sub> propagation delay	SVSHE = 1, dV <sub>DVCC</sub> /dt = 10 mV/μs, SVSHFP = 1		2.5		μs
		SVSHE = 1, dV <sub>DVCC</sub> /dt = ±1 mV/μs, SVSHFP = 0		25		
$t_{(SVSH)}$	SVS <sub>H</sub> on/off delay time	SVSHE = 0 -> 1 SVSHFP = 1		12.5		μs
		SVSHE = 0 -> 1 SVSHFP = 0		100		
dV <sub>DVCC</sub> /dt	DV <sub>CC</sub> rise time		0		1000	V/s

### PMM, SVM High Side

over recommended ranges of supply voltage and operating free-air temperature (unless otherwise noted)

PARAMETER		TEST CONDITIONS	MIN	TYP	MAX	UNIT
$I_{(SVMH)}$	SVM <sub>H</sub> current consumption	SVMHE = 0, DV <sub>CC</sub> = 3.6 V		0		nA
		SVMHE = 1, DV <sub>CC</sub> = 3.6 V, SVMHFP = 0		200		nA
		SVMHE = 1, DV <sub>CC</sub> = 3.6 V, SVMHFP = 1		2.0		μA
$V_{(SVMH)}$	SVM <sub>H</sub> on/off voltage level	SVMHE = 1, SVSMHRRL = 0	1.65	1.74	1.86	V
		SVMHE = 1, SVSMHRRL = 1	1.85	1.94	2.02	
		SVMHE = 1, SVSMHRRL = 2	2.02	2.14	2.22	
		SVMHE = 1, SVSMHRRL = 3	2.18	2.26	2.35	
		SVMHE = 1, SVSMHRRL = 4	2.32	2.40	2.48	
		SVMHE = 1, SVSMHRRL = 5	2.56	2.70	2.84	
		SVMHE = 1, SVSMHRRL = 6	2.85	3.00	3.15	
		SVMHE = 1, SVSMHRRL = 7	2.85	3.00	3.15	
$t_{pd(SVMH)}$	SVM <sub>H</sub> propagation delay	SVMHE = 1, dV <sub>DVCC</sub> /dt = 10 mV/μs, SVMHFP = 1		2.5		μs
		SVMHE = 1, dV <sub>DVCC</sub> /dt = 1 mV/μs, SVMHFP = 0		20		μs
$t_{(SVMH)}$	SVM <sub>H</sub> on/off delay time	SVMHE = 0 -> 1, SVSHFP = 1		12.5		μs
		SVMHE = 0 -> 1, SVSHFP = 0		100		

### PMM, SVS Low Side

over recommended ranges of supply voltage and operating free-air temperature (unless otherwise noted)

PARAMETER		TEST CONDITIONS	MIN	TYP	MAX	UNIT
$I_{(SVSL)}$	SVS <sub>L</sub> current consumption	SVSLE = 0, PMMCOREV = 2		0		nA
		SVSLE = 1, PMMCOREV = 2, SVSLFP = 0		200		nA
		SVSLE = 1, PMMCOREV = 2, SVSLFP = 1		2.0		μA
$t_{(SVSL)}$	SVS <sub>L</sub> on/off delay time	SVSLE = 1, dV <sub>CORE</sub> /dt = 10 mV/μs, SVSLFP = 1		6		μs
		SVSLE = 1, dV <sub>CORE</sub> /dt = 1 mV/μs, SVSLFP = 0		50		
$t_{pd(SVSL)}$	SVS <sub>L</sub> propagation delay	SVMHE = 0 -> 1, SVSLFP = 1		12.5		μs
		SVMHE = 0 -> 1, SVSLFP = 0		100		

### PMM, SVM Low Side

over recommended ranges of supply voltage and operating free-air temperature (unless otherwise noted)

PARAMETER		TEST CONDITIONS	MIN	TYP	MAX	UNIT
$I_{(SVML)}$	SVM <sub>L</sub> current consumption	SVMLE = 0, PMMCOREV = 2		0		nA
		SVMLE = 1, PMMCOREV = 2, SVMLEFP = 0		200		nA
		SVMLE = 1, PMMCOREV = 2, SVMLEFP = 1		2.0		μA
$t_{pd(SVML)}$	SVM <sub>L</sub> propagation delay	SVMLE = 1, dV <sub>CORE</sub> /dt = 10 mV/μs, SVMLEFP = 1		2.5		μs
		SVMLE = 1, dV <sub>CORE</sub> /dt = 1 mV/μs, SVMLEFP = 0		30		
$t_{(SVML)}$	SVM <sub>L</sub> on/off delay time	SVMLE = 0 -> 1, SVSLFP = 1		12.5		μs
		SVMLE = 0 -> 1, SVSLFP = 0		100		

### Wake-Up From Low-Power Modes

over recommended ranges of supply voltage and operating free-air temperature (unless otherwise noted)

PARAMETER		TEST CONDITIONS	MIN	TYP	MAX	UNIT
t <sub>FAST-WAKE-UP</sub>	Wake-up time from LPM2, LPM3, or LPM4 to active mode	PMMCOREV <sub>x</sub> = 0 = SVSMLRRL <sub>x</sub> = n (where n = 0, 1, 2, or 3), SVSLFP = 1	f <sub>MCLK</sub> ≥ 4 MHz	3	6.5	μs
			1 MHz < f <sub>MCLK</sub> < 4 MHz	4	8.0	
t <sub>SLOW-WAKE-UP</sub>	Wake-up time from LPM2, LPM3, or LPM4 to active mode	PMMCOREV <sub>x</sub> = 0 = SVSMLRRL <sub>x</sub> = n (where n = 0, 1, 2, or 3), SVSLFP = 0	150	165		μs
t <sub>WAKE-UP LPM5</sub>	Wake-up time from LPM4.5 to active mode		2	3		ms
t <sub>WAKE-UP-RESET</sub>	Wake-up time from RST or BOR event to active mode		2	3		ms

### Timer\_A

over recommended ranges of supply voltage and operating free-air temperature (unless otherwise noted)

PARAMETER		TEST CONDITIONS	V <sub>CC</sub>	MIN	TYP	MAX	UNIT
f <sub>TA</sub>	Timer_A input clock frequency	Internal: SMCLK, ACLK External: TACLK Duty cycle = 50% ± 10%	1.8 V / 3 V			25	MHz
t <sub>TA,cap</sub>	Timer_A capture timing	All capture inputs. Minimum pulse width required for capture.	1.8 V / 3 V	20			ns

### USCI (UART Mode)

over recommended ranges of supply voltage and operating free-air temperature (unless otherwise noted)

PARAMETER		TEST CONDITIONS	V <sub>CC</sub>	MIN	TYP	MAX	UNIT
f <sub>USCI</sub>	USCI input clock frequency	Internal: SMCLK, ACLK External: UCLK Duty cycle = 50% ± 10%				f <sub>SYSTEM</sub>	MHz
f <sub>max,BITCLK</sub>	Maximum BITCLK clock frequency (equals baud rate in MBaud) <sup>(1)</sup>			1			MHz
t <sub>r</sub>	UART receive deglitch time		2.2 V	50	150	200	ns
			3 V	50	150	200	

(1) The DCO wake-up time must be considered in LPM3/4. The wake-up time must be considered in LPMx.5.

### USCI (SPI Master Mode)

over recommended ranges of supply voltage and operating free-air temperature (unless otherwise noted) (see [Figure 23](#) and [Figure 24](#))

PARAMETER		TEST CONDITIONS	V <sub>CC</sub>	MIN	TYP	MAX	UNIT
f <sub>USCI</sub>	USCI input clock frequency	SMCLK, ACLK Duty cycle = 50% ± 10%				f <sub>SYSTEM</sub>	MHz
t <sub>SU,MI</sub>	SOMI input data setup time	PMMCOREV = 0	1.8 V	55			ns
			3 V	38			
		PMMCOREV = 3	2.4 V	30			
			3 V	25			
t <sub>HD,MI</sub>	SOMI input data hold time	PMMCOREV = 0	1.8 V	0			ns
			3 V	0			
		PMMCOREV = 3	2.4 V	0			
			3 V	0			
t <sub>VALID,MO</sub>	SIMO output data valid time	UCLK edge to SIMO valid, C <sub>L</sub> = 20 pF, PMMCOREV = 0	1.8 V			20	ns
			3 V			18	
		UCLK edge to SIMO valid, C <sub>L</sub> = 20 pF, PMMCOREV = 3	2.4 V			16	
			3 V			15	
t <sub>HD,MO</sub>	SIMO output data hold time	C <sub>L</sub> = 20 pF PMMCOREV = 0	1.8 V	-10			ns
			3 V	-8			
		C <sub>L</sub> = 20 pF PMMCOREV = 3	2.4 V	-10			ns
			3 V	-8			

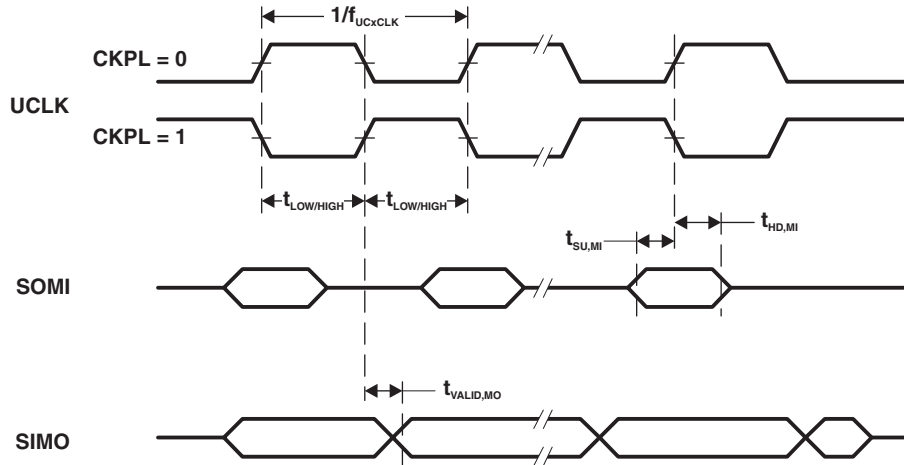

Figure 23. SPI Master Mode, CKPH = 0

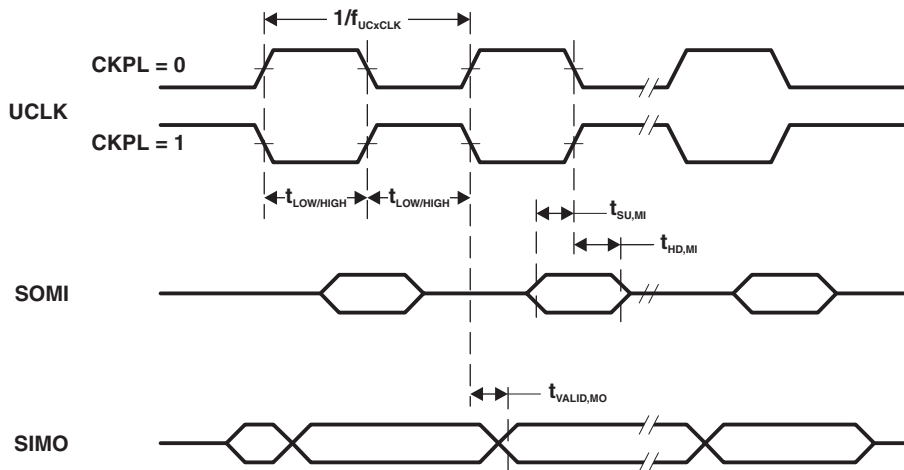

Figure 24. SPI Master Mode, CKPH = 1

## USCI (SPI Slave Mode)

over recommended ranges of supply voltage and operating free-air temperature (unless otherwise noted) (see [Figure 25](#) and [Figure 26](#))

PARAMETER		TEST CONDITIONS	V <sub>CC</sub>	MIN	TYP	MAX	UNIT
t <sub>STE,LEAD</sub>	STE lead time, STE low to clock	PMMCOREV = 0	1.8 V	11			ns
			3 V	8			
		PMMCOREV = 3	2.4 V	7			ns
			3 V	6			
t <sub>STE,LAG</sub>	STE lag time, Last clock to STE high	PMMCOREV = 0	1.8 V	3			ns
			3 V	3			
		PMMCOREV = 3	2.4 V	3			ns
			3 V	3			
t <sub>STE,ACC</sub>	STE access time, STE low to SOMI data out	PMMCOREV = 0	1.8 V			66	ns
			3 V			50	
		PMMCOREV = 3	2.4 V			36	ns
			3 V			30	
t <sub>STE,DIS</sub>	STE disable time, STE high to SOMI high impedance	PMMCOREV = 0	1.8 V			30	ns
			3 V			23	
		PMMCOREV = 3	2.4 V			16	ns
			3 V			13	
t <sub>SU,SI</sub>	SIMO input data setup time	PMMCOREV = 0	1.8 V	5			ns
			3 V	5			
		PMMCOREV = 3	2.4 V	2			ns
			3 V	2			
t <sub>HD,SI</sub>	SIMO input data hold time	PMMCOREV = 0	1.8 V	5			ns
			3 V	5			
		PMMCOREV = 3	2.4 V	5			ns
			3 V	5			
t <sub>VALID,SO</sub>	SOMI output data valid time	UCLK edge to SOMI valid, C <sub>L</sub> = 20 pF PMMCOREV = 0	1.8 V			76	ns
			3 V			60	
		UCLK edge to SOMI valid, C <sub>L</sub> = 20 pF PMMCOREV = 3	2.4 V			44	ns
			3 V			40	
t <sub>HD,SO</sub>	SOMI output data hold time	C <sub>L</sub> = 20 pF PMMCOREV = 0	1.8 V	18			ns
			3 V	12			
		C <sub>L</sub> = 20 pF PMMCOREV = 3	2.4 V	10			ns
			3 V	8			

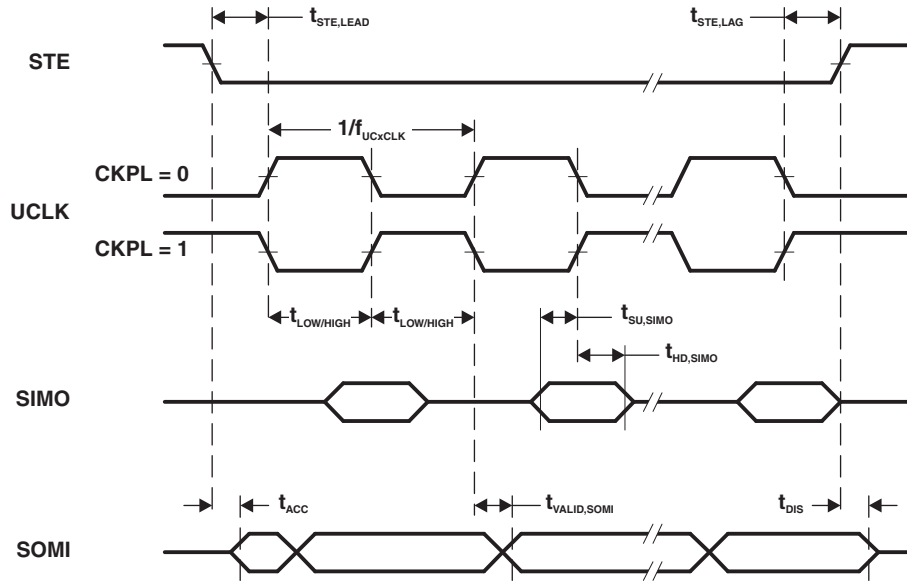

Figure 25. SPI Slave Mode, CKPH = 0

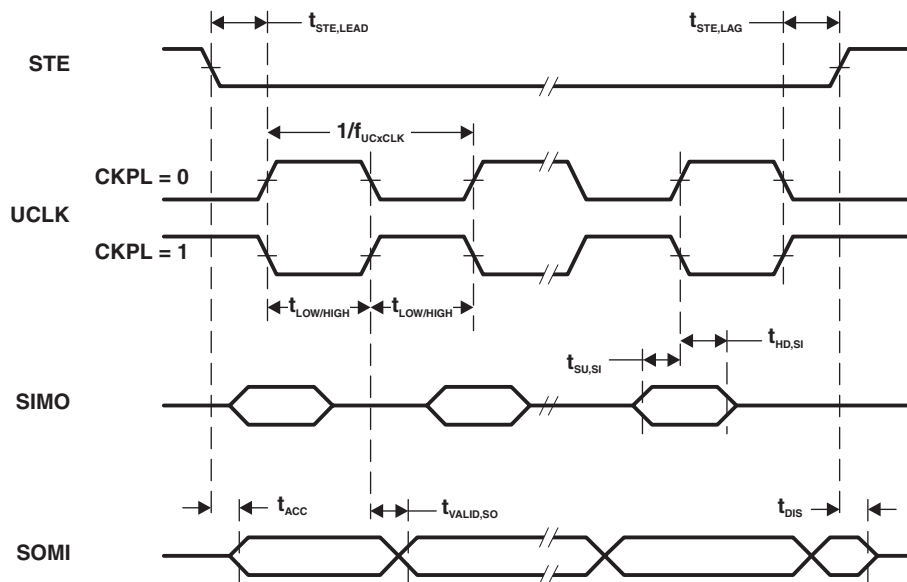

Figure 26. SPI Slave Mode, CKPH = 1

## USCI (I2C Mode)

over recommended ranges of supply voltage and operating free-air temperature (unless otherwise noted) (see [Figure 27](#))

PARAMETER	TEST CONDITIONS	V <sub>CC</sub>	MIN	TYP	MAX	UNIT
f <sub>USCI</sub>	USCI input clock frequency				f <sub>SYSTEM</sub>	MHz
f <sub>SCL</sub>	SCL clock frequency	2.2 V/3 V	0		400	kHz
t <sub>HD,STA</sub>	Hold time (repeated) START	f <sub>SCL</sub> ≤ 100 kHz f <sub>SCL</sub> > 100 kHz	4.0			μs
t <sub>SU,STA</sub>	Setup time for a repeated START	f <sub>SCL</sub> ≤ 100 kHz f <sub>SCL</sub> > 100 kHz	4.7			μs
t <sub>HD,DAT</sub>	Data hold time	2.2 V/3 V	0			ns
t <sub>SU,DAT</sub>	Data setup time	2.2 V/3 V	250			ns
t <sub>SU,STO</sub>	Setup time for STOP	f <sub>SCL</sub> ≤ 100 kHz f <sub>SCL</sub> > 100 kHz	4.0			μs
t <sub>SP</sub>	Pulse width of spikes suppressed by input filter	2.2 V 3 V	50		600	ns

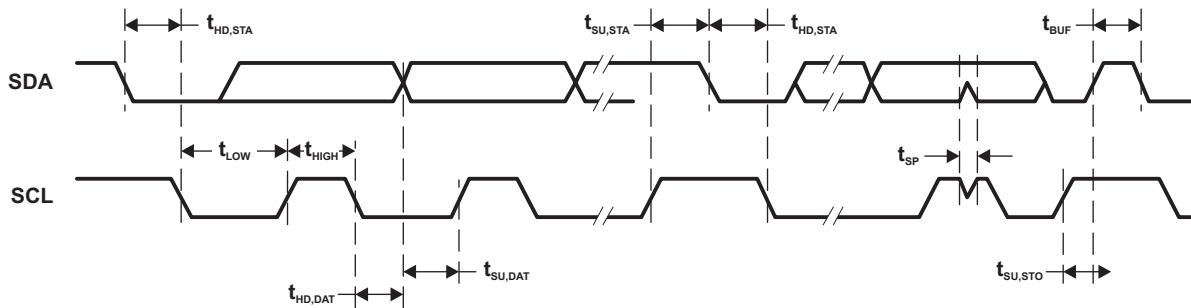

Figure 27. I2C Mode Timing

### 10-Bit ADC, Power Supply and Input Range Conditions (MSP430F51x2 Devices Only)

over recommended ranges of supply voltage and operating free-air temperature (unless otherwise noted)<sup>(1)</sup>

PARAMETER		TEST CONDITIONS	V <sub>CC</sub>	MIN	TYP	MAX	UNIT
AV <sub>CC</sub>	Analog supply voltage	AV <sub>CC</sub> and DV <sub>CC</sub> are connected together, AV <sub>SS</sub> and DV <sub>SS</sub> are connected together, V <sub>(AVSS)</sub> = V <sub>(DVSS)</sub> = 0 V		1.8		3.6	V
V <sub>(Ax)</sub>	Analog input voltage range <sup>(2)</sup>	All ADC10_A pins: P1.0 to P1.5 and P3.6 and P3.7 terminals		0		AV <sub>CC</sub>	V
I <sub>ADC10_A</sub>	Operating supply current into AV <sub>CC</sub> terminal. REF module and reference buffer off.	f <sub>ADC10CLK</sub> = 5 MHz, ADC10ON = 1, REFON = 0, SHT0 = 0, SHT1 = 0, ADC10DIV = 0, ADC10SREF = 00	2.2 V		60	90	μA
			3 V		75	100	
	Operating supply current into AV <sub>CC</sub> terminal. REF module on, reference buffer on.	f <sub>ADC10CLK</sub> = 5 MHz, ADC10ON = 1, REFON = 1, SHT0 = 0, SHT1 = 0, ADC10DIV = 0, ADC10SREF = 01	3 V		113	130	μA
		f <sub>ADC10CLK</sub> = 5 MHz, ADC10ON = 1, REFON = 0, SHT0 = 0, SHT1 = 0, ADC10DIV = 0, ADC10SREF = 10, VREF = 2.5 V	3 V		105	125	μA
Operating supply current into AV <sub>CC</sub> terminal. REF module off, reference buffer off.	f <sub>ADC10CLK</sub> = 5 MHz, ADC10ON = 1, REFON = 0, SHT0 = 0, SHT1 = 0, ADC10DIV = 0, ADC10SREF = 11, VREF = 2.5 V	3 V		70	95	μA	
C <sub>I</sub>	Input capacitance	Only one terminal Ax can be selected at one time from the pad to the ADC10_A capacitor array including wiring and pad.	2.2 V		3.5		pF
R <sub>I</sub>	Input MUX ON resistance	AV <sub>CC</sub> > 2.0V, 0 V ≤ V <sub>Ax</sub> ≤ AV <sub>CC</sub>				36	kΩ
		1.8V < AV <sub>CC</sub> < 2.0V, 0 V ≤ V <sub>Ax</sub> ≤ AV <sub>CC</sub>				96	

- (1) The leakage current is defined in the leakage current table with P6.x/Ax parameter.  
 (2) The analog input voltage range must be within the selected reference voltage range V<sub>R+</sub> to V<sub>R-</sub> for valid conversion results. The external reference voltage requires decoupling capacitors. See <sup>0</sup>.

### 10-Bit ADC, Timing Parameters (MSP430F51x2 Devices Only)

over recommended ranges of supply voltage and operating free-air temperature (unless otherwise noted)

PARAMETER		TEST CONDITIONS	V <sub>CC</sub>	MIN	TYP	MAX	UNIT
f <sub>ADC10CLK</sub>		For specified performance of ADC10_A linearity parameters	2.2 V/3 V	0.45	5	5.5	MHz
f <sub>ADC10OSC</sub>	Internal ADC10_A oscillator <sup>(1)</sup>	ADC10DIV = 0, f <sub>ADC10CLK</sub> = f <sub>ADC10OSC</sub>	2.2 V/3 V	4.2	4.8	5.4	MHz
t <sub>CONVERT</sub>	Conversion time	REFON = 0, Internal oscillator, 12 ADC10CLK cycles, 10-bit mode f <sub>ADC10OSC</sub> = 4 MHz to 5 MHz	2.2 V/3 V	2.4		3.0	μs
		External f <sub>ADC10CLK</sub> from ACLK, MCLK or SMCLK, ADC10SSEL ≠ 0			(2)		
t <sub>ADC10ON</sub>	Turn on settling time of the ADC	See <sup>(3)</sup>				100	ns
t <sub>Sample</sub>	Sampling time	R <sub>S</sub> = 1000 Ω, R <sub>I</sub> = 96 kΩ, C <sub>I</sub> = 3.5 pF <sup>(4)</sup>	1.8 V	3			μs
		R <sub>S</sub> = 1000 Ω, R <sub>I</sub> = 36 kΩ, C <sub>I</sub> = 3.5 pF <sup>(4)</sup>	3 V	1			μs

- (1) The ADC10OSC is sourced directly from MODOSC inside the UCS.  
 (2)  $12 \times \text{ADC10DIV} \times 1/f_{\text{ADC10CLK}}$   
 (3) The condition is that the error in a conversion started after t<sub>ADC10ON</sub> is less than ±0.5 LSB. The reference and input signal are already settled.  
 (4) Approximately eight Tau (τ) are needed to get an error of less than ±0.5 LSB

## 10-Bit ADC, Linearity Parameters (MSP430F51x2 Devices Only)

over recommended ranges of supply voltage and operating free-air temperature (unless otherwise noted)

PARAMETER		TEST CONDITIONS	V <sub>CC</sub>	MIN	TYP	MAX	UNIT
E <sub>I</sub>	Integral linearity error	1.4 V ≤ (VEREF+ – VEREF-)min ≤ 1.6 V				±1.0	LSB
		1.6 V < (VEREF+ – VEREF-)min ≤ V <sub>AVCC</sub>				±1.0	
E <sub>D</sub>	Differential linearity error	(VEREF+ – VEREF-)min ≤ (VEREF+ – VEREF-), C <sub>VEREF+</sub> = 20 pF				±1.0	LSB
E <sub>O</sub>	Offset error	(VEREF+ – VEREF-)min ≤ (VEREF+ – VEREF-), Internal impedance of source R <sub>S</sub> < 100 Ω, C <sub>VEREF+</sub> = 20 pF				±1.0	LSB
E <sub>G</sub>	Gain error, external reference	(VEREF+ – VEREF-)min ≤ (VEREF+ – VEREF-), C <sub>VEREF+</sub> = 20 pF				±1.0	LSB
	Gain error, external reference, buffered					±1.5	
	Gain error, internal reference	See (1)				±1.5%	VREF
E <sub>T</sub>	Total unadjusted error, external buffered and unbuffered reference	(VEREF+ – VEREF-)min ≤ (VEREF+ – VEREF-), C <sub>VEREF+</sub> = 20 pF			±1.0	±2.0	LSB
	Total unadjusted error, internal reference	See (1)				±1.5%	VREF

(1) Dominated by the absolute voltage of the integrated reference voltage.

## REF, External Reference (MSP430F51x2 Devices Only)

over recommended ranges of supply voltage and operating free-air temperature (unless otherwise noted)<sup>(1)</sup>

PARAMETER		TEST CONDITIONS	V <sub>CC</sub>	MIN	TYP	MAX	UNIT
VEREF+	Positive external reference voltage input	VEREF+ > VEREF- (2)		1.4		V <sub>CC</sub>	V
VEREF-	Negative external reference voltage input	VEREF+ > VEREF- (3)		0		1.2	V
VEREF+ – VEREF-	Differential external reference voltage input	VEREF+ > VEREF- (4)		1.4		V <sub>CC</sub>	V
I <sub>(VEREF+)</sub> I <sub>(VEREF-)</sub>	Static input current	1.4 V ≤ VEREF+ ≤ V(AVCC), VEREF- = 0 V, f <sub>ADC10CLK</sub> = 5 MHz, ADC10SHTX = 0x0001, Conversion rate 200 ksps	2.2 V/3 V		±8.5	±26	μA
		1.4 V ≤ VEREF+ ≤ V(AVCC), VEREF- = 0 V, f <sub>ADC10CLK</sub> = 5 MHz, ADC10SHTX = 0x1000, Conversion rate 20 ksps	2.2 V/3 V			±1	μA
C <sub>(VEREF+/-)</sub>	Capacitance at VEREF+/- terminal	See (5)		10			μF

- The external reference is used during ADC conversion to charge and discharge the capacitance array. The input capacitance, C<sub>I</sub>, is also the dynamic load for an external reference during conversion. The dynamic impedance of the reference supply should follow the recommendations on analog-source impedance to allow the charge to settle for 12-bit accuracy.
- The accuracy limits the minimum positive external reference voltage. Lower reference voltage levels may be applied with reduced accuracy requirements.
- The accuracy limits the maximum negative external reference voltage. Higher reference voltage levels may be applied with reduced accuracy requirements.
- The accuracy limits minimum external differential reference voltage. Lower differential reference voltage levels may be applied with reduced accuracy requirements.
- Two decoupling capacitors, 10 μF and 100 nF, should be connected to VEREF to decouple the dynamic current required for an external reference source if it is used for the ADC10\_A. See also the *MSP430x5xx/MSP430x6xx Family User's Guide* (SLAU208).

## REF, Built-In Reference (MSP430F51x2 Devices Only)

over recommended ranges of supply voltage and operating free-air temperature (unless otherwise noted)<sup>(1)</sup>

PARAMETER	TEST CONDITIONS	V <sub>CC</sub>	MIN	TYP	MAX	UNIT
V <sub>REF+</sub>	REFVSEL = {2} for 2.5 V, REFON = 1	3 V		2.51	±1.5%	V
	REFVSEL = {1} for 2.0 V, REFON = 1	3 V		1.99	±1.5%	
	REFVSEL = {0} for 1.5 V, REFON = 1	2.2 V/ 3 V		1.5	±1.5%	
AV <sub>CC(min)</sub>	REFVSEL = {0} for 1.5 V		1.8			V
	REFVSEL = {1} for 2.0 V		2.3			
	REFVSEL = {2} for 2.5 V		2.8			
I <sub>REF+</sub>	f <sub>ADC10CLK</sub> = 5 MHz, REFON = 1, REFBURST = 0, REFVSEL = {0} for 1.5 V	3 V		15.5	19	μA
	f <sub>ADC10CLK</sub> = 5 MHz, REFON = 1, REFBURST = 0, REFVSEL = {1} for 2.0 V	3 V		18	24	μA
	f <sub>ADC10CLK</sub> = 5 MHz, REFON = 1, REFBURST = 0, REFVSEL = {2} for 2.5 V	3 V		21	30	μA
TC <sub>REF+</sub>	REFVSEL = (0, 1, 2), REFON = 1			30	50	ppm/ °C
I <sub>SENSOR</sub>	REFON = 1, INCH = 0Ah, ADC10ON = 1, T <sub>A</sub> = 30°C	2.2 V		150	180	μA
		3 V		150	190	
V <sub>SENSOR</sub>	See <sup>(5)</sup> REFON = 1, INCH = 0Ah, ADC10ON = 1, T <sub>A</sub> = 30°C	2.2 V		765		mV
		3 V		765		
V <sub>MID</sub>	ADC10ON = 1, INCH = 0Ah, V <sub>MID</sub> is ~0.5 × V <sub>AVCC</sub>	2.2 V	1.06	1.1	1.14	V
		3 V	1.46	1.5	1.54	
t <sub>SENSOR (sample)</sub>	ADC10ON = 1, INCH = 0Ah, Error of conversion result ≤ 1 LSB			30		μs
t <sub>V<sub>MID</sub> (sample)</sub>	ADC10ON = 1, INCH = 0Ah, Error of conversion result ≤ 1 LSB			1		μs
PSRR <sub>DC</sub>	AV <sub>CC</sub> = AV <sub>CC (min)</sub> - AV <sub>CC(max)</sub> , T <sub>A</sub> = 25°C, REFVSEL = (0, 1, 2), REFON = 1			120	300	μV/V
PSRR <sub>AC</sub>	AV <sub>CC</sub> = AV <sub>CC (min)</sub> - AV <sub>CC(max)</sub> , T <sub>A</sub> = 25°C, f = 1 kHz, ΔV <sub>pp</sub> = 100 mV, REFVSEL = (0, 1, 2), REFON = 1			6.4		mV/V
t <sub>SETTLE</sub>	AV <sub>CC</sub> = AV <sub>CC (min)</sub> - AV <sub>CC(max)</sub> , REFVSEL = (0, 1, 2), REFON = 0 → 1	T <sub>A</sub> = -40°C to 85°C		23	125	μs
		T <sub>A</sub> = 25°C		23	50	
		T <sub>A</sub> = 85°C		16	25	

- (1) The leakage current is defined in the leakage current table with P6.x/Ax parameter.
- (2) The internal reference current is supplied via terminal AV<sub>CC</sub>. Consumption is independent of the ADC10ON control bit, unless a conversion is active. The REFON bit enables to settle the built-in reference before starting an A/D conversion.
- (3) Calculated using the box method: (MAX(-40 to 85°C) – MIN(-40 to 85°C)) / MIN(-40 to 85°C)/(85°C – (-40°C)).
- (4) The sensor current I<sub>SENSOR</sub> is consumed if (ADC10ON = 1 and REFON = 1) or (ADC10ON = 1 and INCH = 0Ah and sample signal is high). When REFON = 1, I<sub>SENSOR</sub> is already included in I<sub>REF+</sub>.
- (5) The temperature sensor offset can be as much as ±20°C. A single-point calibration is recommended in order to minimize the offset error of the built-in temperature sensor.
- (6) The typical equivalent impedance of the sensor is 51 kΩ. The sample time required includes the sensor-on time t<sub>SENSOR(on)</sub>.
- (7) The on-time t<sub>V<sub>MID</sub>(on)</sub> is included in the sampling time t<sub>V<sub>MID</sub>(sample)</sub>; no additional on time is needed.
- (8) The condition is that the error in a conversion started after t<sub>REFON</sub> is less than ±0.5 LSB.

## Comparator\_B

over recommended ranges of supply voltage and operating free-air temperature (unless otherwise noted)

PARAMETER	TEST CONDITIONS	V <sub>CC</sub>	MIN	TYP	MAX	UNIT		
V <sub>CC</sub>	Supply voltage		1.8		3.6	V		
I <sub>AVCC_COMP</sub>	Comparator operating supply current into AV <sub>CC</sub> . Excludes reference resistor ladder.	CBPWRMD = 00, CBON = 1, CBRSx = 00	1.8 V		38	μA		
			2.2 V		31			
			3 V		32			
		CBPWRMD = 01, CBON = 1, CBRSx = 00	2.2/3 V		10	17		
	CBPWRMD = 10, CBON = 1, CBRSx = 00	2.2/3 V		0.2	0.85			
V <sub>REF</sub>	Reference voltage level		CBREFLx = 01, CBREFACC = 0	≥1.8 V	1.5	±1.5%	V	
			CBREFLx = 10, CBREFACC = 0	≥2.2 V	2.0	±1.5%		
			CBREFLx = 11, CBREFACC = 0	≥3.0 V	2.5	±1.5%		
I <sub>AVCC_REF</sub>	Quiescent current of resistor ladder into AV <sub>CC</sub> . Including REF module current.		CBREFACC = 0, CBREFLx = 01, CBRSx = 10, REFON = 0, CBON = 0	2.2/3 V	10	17	μA	
			CBREFACC = 1, CBREFLx = 01, CBRSx = 10, REFON = 0, CBON = 0	2.2/3 V		33	40	μA
V <sub>IC</sub>	Common mode input range		0		V <sub>CC</sub> -1	V		
V <sub>OFFSET</sub>	Input offset voltage		CBPWRMD = 00			±20	mV	
			CBPWRMD = 01, 10			±10	mV	
C <sub>IN</sub>	Input capacitance			5		pF		
R <sub>SIN</sub>	Series input resistance		ON - switch closed			3	4	kΩ
			OFF - switch opened		50			MΩ
t <sub>PD</sub>	Propagation delay, response time		CBPWRMD = 00, CBF = 0			450	ns	
			CBPWRMD = 01, CBF = 0			600	ns	
			CBPWRMD = 10, CBF = 0			50	μs	
t <sub>PD,filter</sub>	Propagation delay with filter active		CBPWRMD = 00, CBON = 1, CBF = 1, CBF <sub>DLY</sub> = 00		0.35	0.6	1.5	μs
			CBPWRMD = 00, CBON = 1, CBF = 1, CBF <sub>DLY</sub> = 01		0.6	1.0	1.8	μs
			CBPWRMD = 00, CBON = 1, CBF = 1, CBF <sub>DLY</sub> = 10		1.0	1.8	3.4	μs
			CBPWRMD = 00, CBON = 1, CBF = 1, CBF <sub>DLY</sub> = 11		1.8	3.4	6.5	μs
t <sub>EN_CMP</sub>	Comparator enable time		CBON = 0 to CBON = 1, CBPWRMD = 00, 01			1	2	μs
			CBON = 0 to CBON = 1, CBPWRMD = 10				1.5	μs
t <sub>EN_REF</sub>	Resistor reference enable time		CBON = 0 to CBON = 1			1.0	1.5	μs
T <sub>CREF</sub>	Temperature coefficient reference					50	ppm/°C	
V <sub>CB_REF</sub>	Reference voltage for a given tap	V <sub>IN</sub> = reference into resistor ladder, n = 0 to 31		$\frac{V_{IN} \times (n+0.5)}{32}$	$\frac{V_{IN} \times (n+1)}{32}$	$\frac{V_{IN} \times (n+1.5)}{32}$	V	

### Timer\_D, Power Supply and Reference Clock Conditions

over recommended ranges of supply voltage and operating free-air temperature (unless otherwise noted)<sup>(1)</sup>

PARAMETER		TEST CONDITIONS	V <sub>CC</sub>	MIN	TYP	MAX	UNIT
DV <sub>CC</sub>	Digital supply voltage	V <sub>(DVSS)</sub> = 0 V		1.8		3.6	V
f <sub>REF,DCO</sub>	Timer_D input reference clock frequency	PMMCOREVx = 0	1.8 V ≤ V <sub>CC</sub> ≤ 3.6 V	8		12.0	MHz
		PMMCOREVx = 1	2.0 V ≤ V <sub>CC</sub> ≤ 3.6 V	8		16.0	
		PMMCOREVx = 2	2.2 V ≤ V <sub>CC</sub> ≤ 3.6 V	8		20.0	
		PMMCOREVx = 3	2.4 V ≤ V <sub>CC</sub> ≤ 3.6 V	8		25.5	
I <sub>(64MHz)</sub>	I <sub>(DVCC)</sub> at 64-MHz Timer_D clock, clock generator only	f <sub>reference</sub> = 8 MHz, MCx = 0, TDHREGEN = 1, TDHMx = 0, TDHCLKCR = 0			253	320	μA
I <sub>(128MHz)</sub>	I <sub>(DVCC)</sub> at 128-MHz Timer_D clock, clock generator only	f <sub>reference</sub> = 16 MHz, MCx = 0, TDHREGEN = 1, TDHMx = 0, TDHCLKCR = 0			285	360	μA
I <sub>(200MHz)</sub>	I <sub>(DVCC)</sub> at 200-MHz Timer_D clock, clock generator only	f <sub>reference</sub> = 25 MHz, MCx = 0, TDHREGEN = 1, TDHMx = 0, TDHCLKCR = 1			280	345	μA
I <sub>(256MHz)</sub>	I <sub>(DVCC)</sub> at 256-MHz Timer_D clock, clock generator only	f <sub>reference</sub> = 16 MHz, MCx = 0, TDHREGEN = 1, TDHMx = 1, TDHCLKCR = 1			265	330	μA
I <sub>(0,16,64)</sub>	I <sub>(DVCC)</sub>	TDHCLKRx = 0, TDHCLKSRx = 16, TDHCLKTRIM = 64	2.2 V		244		μA
			3.0 V		295	325	
I <sub>(1,16,64)</sub>	I <sub>(DVCC)</sub>	TDHCLKRx = 1, TDHCLKSRx = 16, TDHCLKTRIM = 64	2.2 V		282		μA
			3.0 V		300	400	
I <sub>(2,16,64)</sub>	I <sub>(DVCC)</sub>	TDHCLKRx = 2, TDHCLKSRx = 16, TDHCLKTRIM = 64	2.2 V		358		μA
			3.0 V		414	470	

(1) The leakage current is defined in the leakage current table with P6.x/Ax parameter.

## Timer\_D, Local Clock Generator Frequency

over recommended ranges of supply voltage and operating free-air temperature (unless otherwise noted)

PARAMETER		TEST CONDITIONS	MIN	TYP	MAX	UNIT
$f_{\text{HRCG}(0,0,64)}$	HRCG frequency (0, 0, 64)	TDHREGEN = 0, TDHMx = 0, TDHCLKCR = 1, TDHCLKRx = 0, TDHCLKSRx = 0, TDHCLKTRIM = 64	39	56	73	MHz
		TDHREGEN = 0, TDHMx = 1, TDHCLKCR = 1, TDHCLKRx = 0, TDHCLKSRx = 0, TDHCLKTRIM = 64	78	112	146	MHz
$f_{\text{HRCG}(0,7,64)}$	HRCG frequency (0, 7, 64)	TDHREGEN = 0, TDHMx = 0, TDHCLKCR = 1, TDHCLKRx = 0, TDHCLKSRx = 7, TDHCLKTRIM = 64	46	66	86	MHz
		TDHREGEN = 0, TDHMx = 1, TDHCLKCR = 1, TDHCLKRx = 0, TDHCLKSRx = 7, TDHCLKTRIM = 64	92	132	172	MHz
$f_{\text{HRCG}(0,15,64)}$	HRCG frequency (0, 15, 64)	TDHREGEN = 0, TDHMx = 0, TDHCLKCR = 1, TDHCLKRx = 0, TDHCLKSRx = 15, TDHCLKTRIM = 64	55	78	101	MHz
		TDHREGEN = 0, TDHMx = 1, TDHCLKCR = 1, TDHCLKRx = 0, TDHCLKSRx = 15, TDHCLKTRIM = 64	110	156	202	MHz
$f_{\text{HRCG}(0,23,64)}$	HRCG frequency (0, 23, 64)	TDHREGEN = 0, TDHMx = 0, TDHCLKCR = 1, TDHCLKRx = 0, TDHCLKSRx = 23, TDHCLKTRIM = 64	61	87	113	MHz
		TDHREGEN = 0, TDHMx = 1, TDHCLKCR = 1, TDHCLKRx = 0, TDHCLKSRx = 23, TDHCLKTRIM = 64	122	174	226	MHz
$f_{\text{HRCG}(0,31,0)}$	HRCG frequency (0, 31, 0)	TDHREGEN = 0, TDHMx = 0, TDHCLKCR = 1, TDHCLKRx = 0, TDHCLKSRx = 31, TDHCLKTRIM = 0	36	56	73	MHz
		TDHREGEN = 0, TDHMx = 1, TDHCLKCR = 1, TDHCLKRx = 0, TDHCLKSRx = 31, TDHCLKTRIM = 0	72	112	146	MHz
$f_{\text{HRCG}(0,31,64)}$	HRCG frequency (0, 31, 64)	TDHREGEN = 0, TDHMx = 0, TDHCLKCR = 1, TDHCLKRx = 0, TDHCLKSRx = 31, TDHCLKTRIM = 64	68	98	128	MHz
		TDHREGEN = 0, TDHMx = 1, TDHCLKCR = 1, TDHCLKRx = 0, TDHCLKSRx = 31, TDHCLKTRIM = 64	136	196	256	MHz
$f_{\text{HRCG}(0,31,128)}$	HRCG frequency (0, 31, 128)	TDHREGEN = 0, TDHMx = 0, TDHCLKCR = 1, TDHCLKRx = 0, TDHCLKSRx = 31, TDHCLKTRIM = 128	97	138	180	MHz
		TDHREGEN = 0, TDHMx = 1, TDHCLKCR = 1, TDHCLKRx = 0, TDHCLKSRx = 31, TDHCLKTRIM = 128	196	176	360	MHz
$f_{\text{HRCG}(1,0,64)}$	HRCG frequency (1, 0, 64)	TDHREGEN = 0, TDHMx = 0, TDHCLKCR = 0, TDHCLKRx = 1, TDHCLKSRx = 0, TDHCLKTRIM = 64	71	101	131	MHz
		TDHREGEN = 0, TDHMx = 1, TDHCLKCR = 0, TDHCLKRx = 1, TDHCLKSRx = 0, TDHCLKTRIM = 64	142	202	262	MHz
$f_{\text{HRCG}(1,7,64)}$	HRCG frequency (1, 7, 64)	TDHREGEN = 0, TDHMx = 0, TDHCLKCR = 0, TDHCLKRx = 1, TDHCLKSRx = 7, TDHCLKTRIM = 64	84	120	156	MHz
		TDHREGEN = 0, TDHMx = 1, TDHCLKCR = 0, TDHCLKRx = 1, TDHCLKSRx = 7, TDHCLKTRIM = 64	168	240	312	MHz

**Timer\_D, Local Clock Generator Frequency (continued)**

over recommended ranges of supply voltage and operating free-air temperature (unless otherwise noted)

PARAMETER		TEST CONDITIONS	MIN	TYP	MAX	UNIT
f <sub>HRCG(1,15,64)</sub>	HRCG frequency (1, 15, 64)	TDHREGEN = 0, TDHMx = 0, TDHCLKCR = 0, TDHCLKRx = 1, TDHCLKSRx = 15, TDHCLKTRIM = 64	97	139	182	MHz
		TDHREGEN = 0, TDHMx = 1, TDHCLKCR = 0, TDHCLKRx = 1, TDHCLKSRx = 15, TDHCLKTRIM = 64	196	278	364	MHz
f <sub>HRCG(1,23,64)</sub>	HRCG frequency (1, 23, 64)	TDHREGEN = 0, TDHMx = 0, TDHCLKCR = 0, TDHCLKRx = 1, TDHCLKSRx = 23, TDHCLKTRIM = 64	108	154	200	MHz
		TDHREGEN = 0, TDHMx = 1, TDHCLKCR = 0, TDHCLKRx = 1, TDHCLKSRx = 23, TDHCLKTRIM = 64	216	308	400	MHz
f <sub>HRCG(1,31,0)</sub>	HRCG frequency (1, 31, 0)	TDHREGEN = 0, TDHMx = 0, TDHCLKCR = 0, TDHCLKRx = 1, TDHCLKSRx = 31, TDHCLKTRIM = 0	68	97	126	MHz
		TDHREGEN = 0, TDHMx = 1, TDHCLKCR = 0, TDHCLKRx = 1, TDHCLKSRx = 31, TDHCLKTRIM = 0	136	194	252	MHz
f <sub>HRCG(1,31,64)</sub>	HRCG frequency (1, 31, 64)	TDHREGEN = 0, TDHMx = 0, TDHCLKCR = 0, TDHCLKRx = 1, TDHCLKSRx = 31, TDHCLKTRIM = 64	123	175	227	MHz
		TDHREGEN = 0, TDHMx = 1, TDHCLKCR = 0, TDHCLKRx = 1, TDHCLKSRx = 31, TDHCLKTRIM = 64	246	350	454	MHz
f <sub>HRCG(1,31,128)</sub>	HRCG frequency (1, 31, 128)	TDHREGEN = 0, TDHMx = 0, TDHCLKCR = 0, TDHCLKRx = 1, TDHCLKSRx = 31, TDHCLKTRIM = 128	169	241	313	MHz
		TDHREGEN = 0, TDHMx = 1, TDHCLKCR = 0, TDHCLKRx = 1, TDHCLKSRx = 31, TDHCLKTRIM = 128	338	482	616	MHz
f <sub>HRCG(2,0,64)</sub>	HRCG frequency (2, 0, 64)	TDHREGEN = 0, TDHMx = 0, TDHCLKCR = 1, TDHCLKRx = 2, TDHCLKSRx = 0, TDHCLKTRIM = 64	126	180	234	MHz
		TDHREGEN = 0, TDHMx = 1, TDHCLKCR = 1, TDHCLKRx = 1, TDHCLKSRx = 0, TDHCLKTRIM = 64	252	360	468	MHz
f <sub>HRCG(2,7,64)</sub>	HRCG frequency (2, 7, 64)	TDHREGEN = 0, TDHMx = 0, TDHCLKCR = 1, TDHCLKRx = 2, TDHCLKSRx = 7, TDHCLKTRIM = 64	138	208	270	MHz
		TDHREGEN = 0, TDHMx = 1, TDHCLKCR = 1, TDHCLKRx = 2, TDHCLKSRx = 7, TDHCLKTRIM = 6	276	416	540	MHz
f <sub>HRCG(2,15,64)</sub>	HRCG frequency (2, 15, 64)	TDHREGEN = 0, TDHMx = 0, TDHCLKCR = 1, TDHCLKRx = 2, TDHCLKSRx = 15, TDHCLKTRIM = 64	168	240	312	MHz
		TDHREGEN = 0, TDHMx = 1, TDHCLKCR = 1, TDHCLKRx = 2, TDHCLKSRx = 15, TDHCLKTRIM = 64	336	480	624	MHz
f <sub>HRCG(2,23,64)</sub>	HRCG frequency (2, 23, 64)	TDHREGEN = 0, TDHMx = 0, TDHCLKCR = 1, TDHCLKRx = 2, TDHCLKSRx = 23, TDHCLKTRIM = 64	189	270	351	MHz
		TDHREGEN = 0, TDHMx = 1, TDHCLKCR = 1, TDHCLKRx = 2, TDHCLKSRx = 23, TDHCLKTRIM = 64	378	540	702	MHz

**Timer\_D, Local Clock Generator Frequency (continued)**

over recommended ranges of supply voltage and operating free-air temperature (unless otherwise noted)

PARAMETER		TEST CONDITIONS	MIN	TYP	MAX	UNIT
$f_{\text{HRCG}(2,31,0)}$	HRCG frequency (2, 31, 0)	TDHREGEN = 0, TDHMx = 0, TDHCLKCR = 1, TDHCLKRx = 2, TDHCLKSRx = 31, TDHCLKTRIM = 0	119	170	221	MHz
		TDHREGEN = 0, TDHMx = 1, TDHCLKCR = 1, TDHCLKRx = 2, TDHCLKSRx = 31, TDHCLKTRIM = 0	238	340	442	MHz
$f_{\text{HRCG}(2,31,64)}$	HRCG frequency (2, 31, 64)	TDHREGEN = 0, TDHMx = 0, TDHCLKCR = 1, TDHCLKRx = 2, DHCLKSRx = 31, TDHCLKTRIM = 64	212	303	394	MHz
		TDHREGEN = 0, TDHMx = 1, TDHCLKCR = 1, TDHCLKRx = 2, DHCLKSRx = 31, TDHCLKTRIM = 64	424	606	788	MHz
$f_{\text{HRCG}(2,31,128)}$	HRCG frequency (2, 31, 128)	TDHREGEN = 0, TDHMx = 0, TDHCLKCR = 1, TDHCLKRx = 2, TDHCLKSRx = 31, TDHCLKTRIM = 128	290	413	537	MHz
		TDHREGEN = 0, TDHMx = 1, TDHCLKCR = 1, TDHCLKRx = 2, TDHCLKSRx = 31, TDHCLKTRIM = 128	580	826	1074	MHz
$S_{\text{HRCG},0,\text{SR}}$	TDHCLKSRx step size in range 0	$S_{\text{HRCGSR}} = f_{\text{HRCGSR}}(\text{HRCGSR}+1) - f_{\text{HRCG}}(\text{HRCGSR})$	120	185	225	kHz
$S_{\text{HRCG},1,\text{SR}}$	TDHCLKSRx step size in range 1	$S_{\text{HRCGSR}} = f_{\text{HRCGSR}}(\text{HRCGSR}+1) - f_{\text{HRCG}}(\text{HRCGSR})$	220	325	395	kHz
$S_{\text{HRCG},2,\text{SR}}$	TDHCLKSRx step size in range 2	$S_{\text{HRCGSR}} = f_{\text{HRCGSR}}(\text{HRCGSR}+1) - f_{\text{HRCG}}(\text{HRCGSR})$	400	555	700	kHz
$S_{\text{HRCG},0,\text{TRIM}}$	0 > = TDHCLKTRIMx < 16, step size in range 0	$S_{\text{HRCGSR}} = f_{\text{HRCGSR}}(\text{HRCGTRIM}+1) - f_{\text{HRCG}}(\text{HRCGTRIM}), \text{TDHCLKSRx} = \text{X, Y, Z}$	55	85	120	kHz
	15 < TDHCLKTRIMx < 49, step size in range 1		40	85	130	kHz
	48 < TDHCLKTRIMx < 64, step size in range 2		40	85	120	kHz
$S_{\text{HRCG},1,\text{TRIM}}$	0 > = TDHCLKTRIMx < 16, step size in range 0	$S_{\text{HRCGSR}} = f_{\text{HRCGSR}}(\text{HRCGTRIM}+1) - f_{\text{HRCG}}(\text{HRCGTRIM}), \text{TDHCLKSRx} = \text{X, Y, Z}$	90	160	230	kHz
	15 < TDHCLKTRIMx < 49, step size in range 1		80	160	230	kHz
	48 < TDHCLKTRIMx < 64, step size in range 2		80	160	230	kHz
$S_{\text{HRCG},2,\text{TRIM}}$	0 > = TDHCLKTRIMx < 16, step size in range 0	$S_{\text{HRCGSR}} = f_{\text{HRCGSR}}(\text{HRCGTRIM}+1) - f_{\text{HRCG}}(\text{HRCGTRIM}), \text{TDHCLKSRx} = \text{X, Y, Z}$	150	230	360	kHz
	15 < TDHCLKTRIMx < 49, step size in range 1		130	230	350	kHz
	48 < TDHCLKTRIMx < 32, step size in range 2		100	230	340	kHz
$df_{\text{HRCG}}/dT$	HRCG frequency temperature drift	$f_{\text{HRCG}} = 8 \text{ MHz}, \text{TDHREGEN} = 0$			±0.17	%/°C
		$f_{\text{HRCG}} = 16 \text{ MHz}, \text{TDHREGEN} = 0$			±0.16	%/°C
		$f_{\text{HRCG}} = 25 \text{ MHz}, \text{TDHREGEN} = 0$			±0.16	%/°C
		$f_{\text{HRCG}} = 8/16/25 \text{ MHz}, \text{TDHREGEN} = 1$		0		%/°C
$df_{\text{HRCG}}/dV_{\text{CORE}}$	HRCG frequency voltage drift	$f_{\text{HRCG}} = 8/16/25 \text{ MHz}, \text{TDHREGEN} = 0$	0		5	%/V
		$f_{\text{HRCG}} = 8/16/25 \text{ MHz}, \text{TDHREGEN} = 1$		0		%/V
$t_{\text{SETTLE}}$	Settling time	TDHEN = 0 -> 1, TDHFW = 0	3	5	9	µs
	Settling time, fast wake-up	TDHEN = 0 -> 1, TDHFW = 1			1.5	µs

### Timer\_D, Trimmed Clock Frequencies

over recommended ranges of supply voltage and operating free-air temperature (unless otherwise noted)

PARAMETER		TEST CONDITIONS	MIN	TYP	MAX	UNIT
Frequency tolerance during trimming			-0.5		+0.5	%
$f_{\text{TRIM}(64\text{MHz})}$	TDHMx = 0, TDHREGEN = 0, TDHCLKCR = 0, TDHxCTL1 = TDHxCTL1_64	$T_A = 25^\circ\text{C}$ , $V_{\text{CC}} = 1.8\text{ V}$	63	64	65	MHz
$f_{\text{TRIM}(128\text{MHz})}$	TDHMx = 0, TDHREGEN = 0, TDHCLKCR = 1, TDHxCTL1 = TDHxCTL1_128	$T_A = 25^\circ\text{C}$ , $V_{\text{CC}} = 2.0\text{ V}$	126	128	130	MHz
$f_{\text{TRIM}(200\text{MHz})}$	TDHMx = 0, TDHREGEN = 0, TDHCLKCR = 1, TDHxCTL1 = TDHxCTL1_200	$T_A = 25^\circ\text{C}$ , $V_{\text{CC}} = 2.4\text{ V}$	197	200	203	MHz
$f_{\text{TRIM}(256\text{MHz})}$	TDHMx = 1, TDHREGEN = 0, TDHCLKCR = 1, TDHxCTL1 = TDHxCTL1_256	$T_A = 25^\circ\text{C}$ , $V_{\text{CC}} = 2.2\text{ V}$	250	256	262	MHz

### Timer\_D, Frequency Multiplication Mode

over recommended ranges of supply voltage and operating free-air temperature (unless otherwise noted)

PARAMETER		TEST CONDITIONS	MIN	TYP	MAX	UNIT
External frequency tolerance				0		%
E(TDHREGEN = 1,64)	$f_{\text{reference}} = 8\text{ MHz}$ , TDHMx = 0, TDHREGEN = 1, TDHCLKCR = 0, TDHCLKRx = 0	$T_A = 25^\circ\text{C}$ , $V_{\text{CC}} = 1.8\text{ V}$	-1		+1	%
E(TDHREGEN = 1,128)	$f_{\text{reference}} = 16\text{ MHz}$ , TDHMx = 0, TDHREGEN = 1, TDHCLKCR = 1, TDHCLKRx = 0	$T_A = 25^\circ\text{C}$ , $V_{\text{CC}} = 2.0\text{ V}$	-1		+1	%
E(TDHREGEN = 1,200)	$f_{\text{reference}} = 25\text{ MHz}$ , TDHMx = 0, TDHREGEN = 1, TDHCLKCR = 1, TDHCLKRx = 0	$T_A = 25^\circ\text{C}$ , $V_{\text{CC}} = 2.4\text{ V}$	-1		+1	%
E(TDHREGEN = 1,256)	$f_{\text{reference}} = 16\text{ MHz}$ , TDHMx = 1, TDHREGEN = 1, TDHCLKCR = 1, TDHCLKRx = 0	$T_A = 25^\circ\text{C}$ , $V_{\text{CC}} = 2.2\text{ V}$	-1		+1	%

## Timer\_D, Input Capture and Output Compare Timing

over recommended ranges of supply voltage and operating free-air temperature (unless otherwise noted)

PARAMETER		TEST CONDITIONS	MIN	TYP	MAX	UNIT
$t_{TD,cap}$	Timer_D input capture timing, minimum pulse width to trigger input capture event	$f_{MAX} = 262 \text{ MHz}$		4		ns
$t_{TD0,cap,matching}$	Timer0_D input capture timing, matching between input capture channels P1.6 to P1.7 and P2.0.	$f_{MAX} = 262 \text{ MHz}$		1	2	LSB
	Timer0_D input capture timing, matching between input capture channels. P2.4 to P2.5 and P2.6.	$f_{MAX} = 262 \text{ MHz}$		3	4	LSB
$t_{TD1,cap,matching}$	Timer1_D input capture timing, matching between input capture channels P2.1 to P2.2 and P2.3.	$f_{MAX} = 262 \text{ MHz}$		2	3	LSB
	Timer1_D input capture timing, matching between input capture channels. P2.7 to P3.0 and P3.1.	$f_{MAX} = 262 \text{ MHz}$		2	4	LSB
$t_{TD01,cap,matching}$	Timer0_D and Timer1_D input capture timing, matching between input capture channels. Timer0_D is the high-resolution clock generator source.	$f_{MAX} = 262 \text{ MHz}$		4	8	LSB
$t_{TD0,comp,matching}$	Timer0_D output compare timing, matching between output capture compare channels for pins P1.6, P1.6 and P2.0	Rising edges, $f_{MAX} = 262 \text{ MHz}$			4	ns
		Falling edges, $f_{MAX} = 262 \text{ MHz}$			4	ns
		Rising and falling edges, $f_{MAX} = 262 \text{ MHz}$			8	ns
$t_{TD1,comp,matching}$	Timer1_D output compare timing, matching between output capture compare channels for pins P2.1, P2.2, and P2.3	Rising edges, $f_{MAX} = 262 \text{ MHz}$			4	ns
		Falling edges, $f_{MAX} = 262 \text{ MHz}$			4	ns
		Rising and falling edges, $f_{MAX} = 262 \text{ MHz}$			8	ns
$t_{TD01,comp,matching}$	Timer0_D and Timer1_D output compare timing, matching between output compare channels. Timer0_D is the high-resolution clock generator source	All edges, $f_{MAX} = 262 \text{ MHz}$			8	LSB

## Flash Memory

over recommended ranges of supply voltage and operating free-air temperature (unless otherwise noted)

PARAMETER		TEST CONDITIONS	MIN	TYP	MAX	UNIT
$DV_{CC(PGM/ERASE)}$	Program and erase supply voltage		1.8		3.6	V
$I_{PGM}$	Supply current from $DV_{CC}$ during program			3	5	mA
$I_{ERASE}$	Supply current from $DV_{CC}$ during erase			2	6.5	mA
$I_{MERASE}, I_{BANK}$	Supply current from $DV_{CC}$ during mass erase or bank erase				2.5	mA
$t_{CPT}$	Cumulative program time	See <sup>(1)</sup>			16	ms
	Program/erase endurance		$10^4$	$10^5$		cycles
$t_{Retention}$	Data retention duration	$T_J = 25^\circ C$	100			years
$t_{Word}$	Word or byte program time	See <sup>(2)</sup>	64		85	$\mu s$
$t_{Block, 0}$	Block program time for first byte or word	See <sup>(2)</sup>	49		65	$\mu s$
$t_{Block, 1-(N-1)}$	Block program time for each additional byte or word, except for last byte or word	See <sup>(2)</sup>	37		49	$\mu s$
$t_{Block, N}$	Block program time for last byte or word	See <sup>(2)</sup>	55		73	$\mu s$
$t_{Mass Erase}$	Mass erase time	See <sup>(2)</sup>	23		32	ms
$t_{Seg Erase}$	Segment erase time	See <sup>(2)</sup>	23		32	ms
$f_{MCLK, MGR}$	MCLK frequency in marginal read mode (FCLK4.MGR0 = 1 or FCTL4.MGR1 = 1)		0		1	MHz

- (1) The cumulative program time must not be exceeded when writing to a 128-byte flash block. This parameter applies to all programming methods: individual word/byte write and block write modes.  
 (2) These values are hardwired into the flash controller's state machine.

## JTAG and Spy-Bi-Wire Interface

over recommended ranges of supply voltage and operating free-air temperature (unless otherwise noted)

PARAMETER		TEST CONDITIONS	MIN	TYP	MAX	UNIT
$f_{SBW}$	Spy-Bi-Wire input frequency	2.2 V/3 V	0		20	MHz
$t_{SBW, Low}$	Spy-Bi-Wire low clock pulse length	2.2 V/3 V	0.025		15	$\mu s$
$t_{SBW, En}$	Spy-Bi-Wire enable time (TEST high to acceptance of first clock edge) <sup>(1)</sup>	2.2 V/3 V			1	$\mu s$
$t_{SBW, Rst}$	Spy-Bi-Wire return to normal operation time		15		100	$\mu s$
$f_{TCK}$	TCK input frequency, 4-wire JTAG <sup>(2)</sup>	2.2 V	0		5	MHz
		3 V	0		10	MHz
$R_{internal}$	Internal pull-down resistance on TEST	2.2 V/3 V	45	60	80	k $\Omega$

- (1) Tools accessing the Spy-Bi-Wire interface need to wait for the minimum  $t_{SBW, En}$  time after pulling the TEST/SBWTCK pin high before applying the first SBWTCK clock edge.  
 (2)  $f_{TCK}$  may be restricted to meet the timing requirements of the module selected.

## INPUT/OUTPUT SCHEMATICS

### Port P1, P1.0 to P1.5, Input/Output With Schmitt Trigger

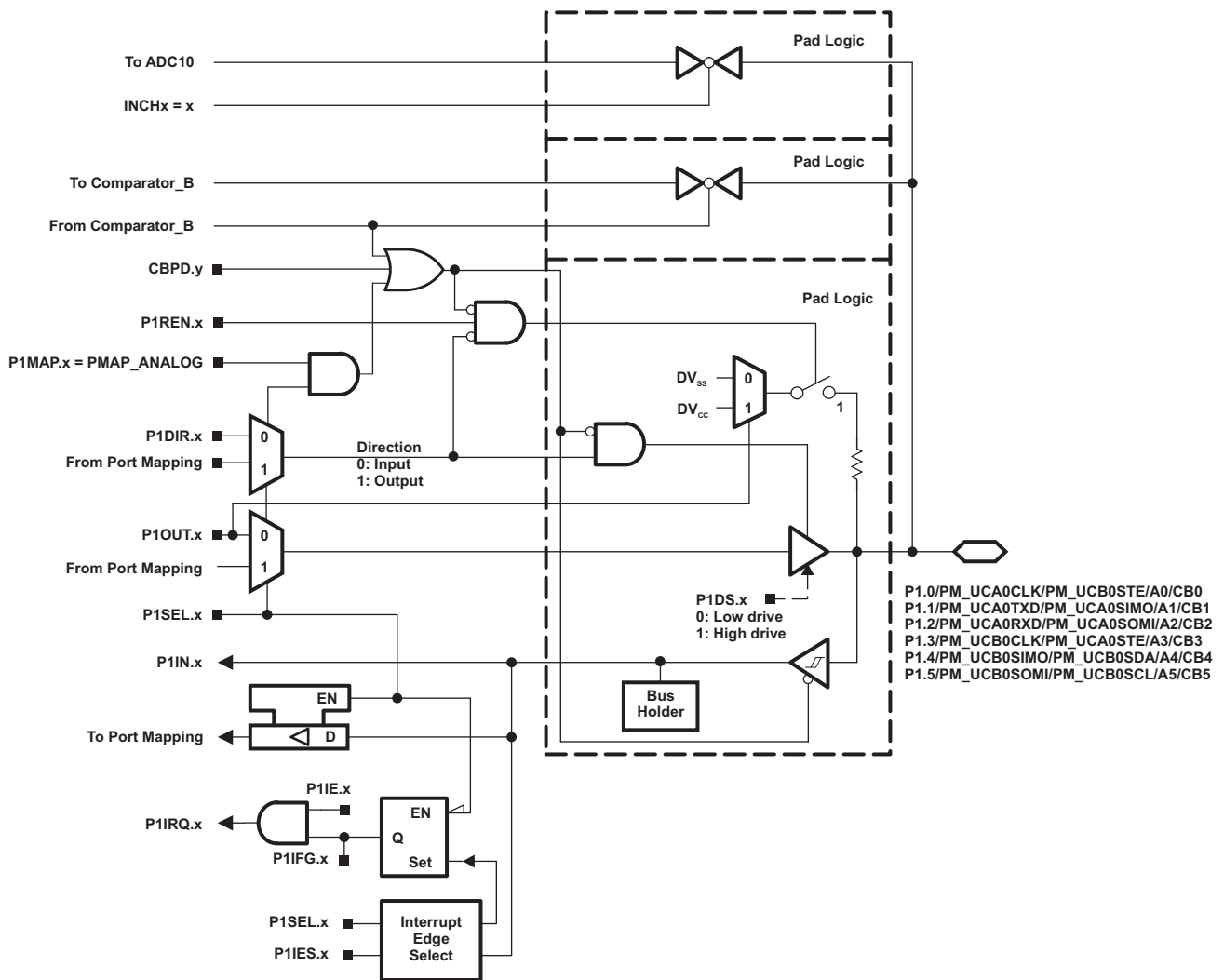

**Table 46. Port P1 (P1.0 to P1.5) Pin Functions**

PIN NAME (P1.x)	x	FUNCTION	CONTROL BITS/SIGNALS <sup>(1)</sup>			
			P1DIR.x	P1SEL.x	P1MAP.x	CBPD.y
P1.0/ PM_UCA0CLK/ PM_UCB0STE/ A0/ CB0	0	P1.x (I/O)	I: 0; O: 1	0	X	0
		UCA0CLK/UCB0STE <sup>(2) (3)</sup>	0	1	default	0
		A0 <sup>(4)</sup>	X	1	31 INCHx = 0	X
		CB0	X	X	X	1 (y = 0)
P1.1/ PM_UCA0TXD/ PM_UCA0SIMO/ A1/ CB1	1	P1.x (I/O)	I: 0; O: 1	0	X	0
		PM_UCA0TXD/PM_UCA0SIMO <sup>(2)</sup>	0	1	default	0
		A1 <sup>(4)</sup>	X	1	31 INCHx = 1	X
		CB1	X	X	X	1 (y = 1)
P1.2/ PM_UCA0RXD/ PM_UCA0SOMI/ A2/ CB2	2	P1.x (I/O)	I: 0; O: 1	0	X	0
		PM_UCA0RXD/PM_UCA0SOMI <sup>(2)</sup>	0	1	default	0
		A2 <sup>(4)</sup>	X	1	31 INCHx = 2	X
		CB2	X	X	X	1 (y = 2)
P1.3/ PM_UCB0CLK/ PM_UCA0STE/ A3/ CB3	3	P1.x (I/O)	I: 0; O: 1	0	X	0
		UCB0CLK/UCA0STE <sup>(2)</sup>	0	1	default	0
		A3 <sup>(4)</sup>	X	1	31 INCHx = 3	X
		CB3	X	X	X	1 (y = 3)
P1.4/ PM_UCB0SIMO/ PM_UCB0SDA/ A4/ CB4	4	P1.x (I/O)	I: 0; O: 1	0	X	0
		PM_UCB0SIMO/PM_UCB0SDA <sup>(2) (5)</sup>	0	1	default	0
		A4 <sup>(4)</sup>	X	1	31 INCHx = 4	X
		CB4	X	X	X	1 (y = 4)
P1.5/ PM_UCB0SOMI/ PM_UCB0SCL/ A5/ CB5	5	P1.x (I/O)	I: 0; O: 1	0	X	0
		PM_UCB0SOMI/PM_UCB0SCL <sup>(2) (5)</sup>	0	1	default	0
		A5 <sup>(4)</sup>	X	1	31 INCHx = 5	X
		CB5	X	X	X	1 (y = 5)

- (1) X = Don't care
- (2) The pin direction is controlled by the USCI module.
- (3) UCA0CLK function takes precedence over UCB0STE function. If the pin is required as UCA0CLK input or output, USCI A0/B0 is forced to 3-wire SPI mode if 4-wire SPI mode is selected.
- (4) MSP430F51x2 device only.
- (5) If the I2C functionality is selected, the output drives only the logical 0 to V<sub>SS</sub> level.

Port P1, P1.6 to P1.7, Input/Output With Schmitt Trigger

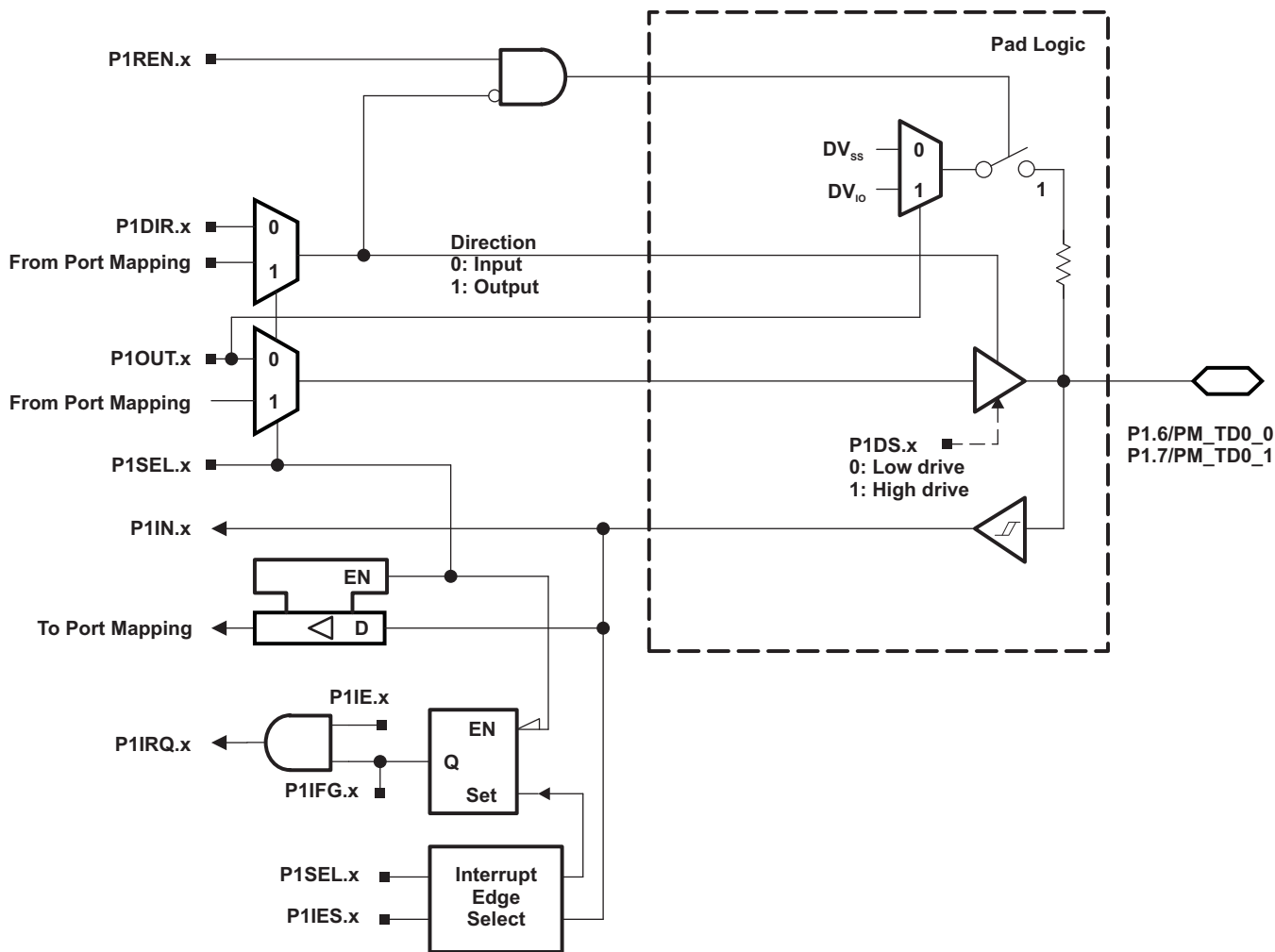
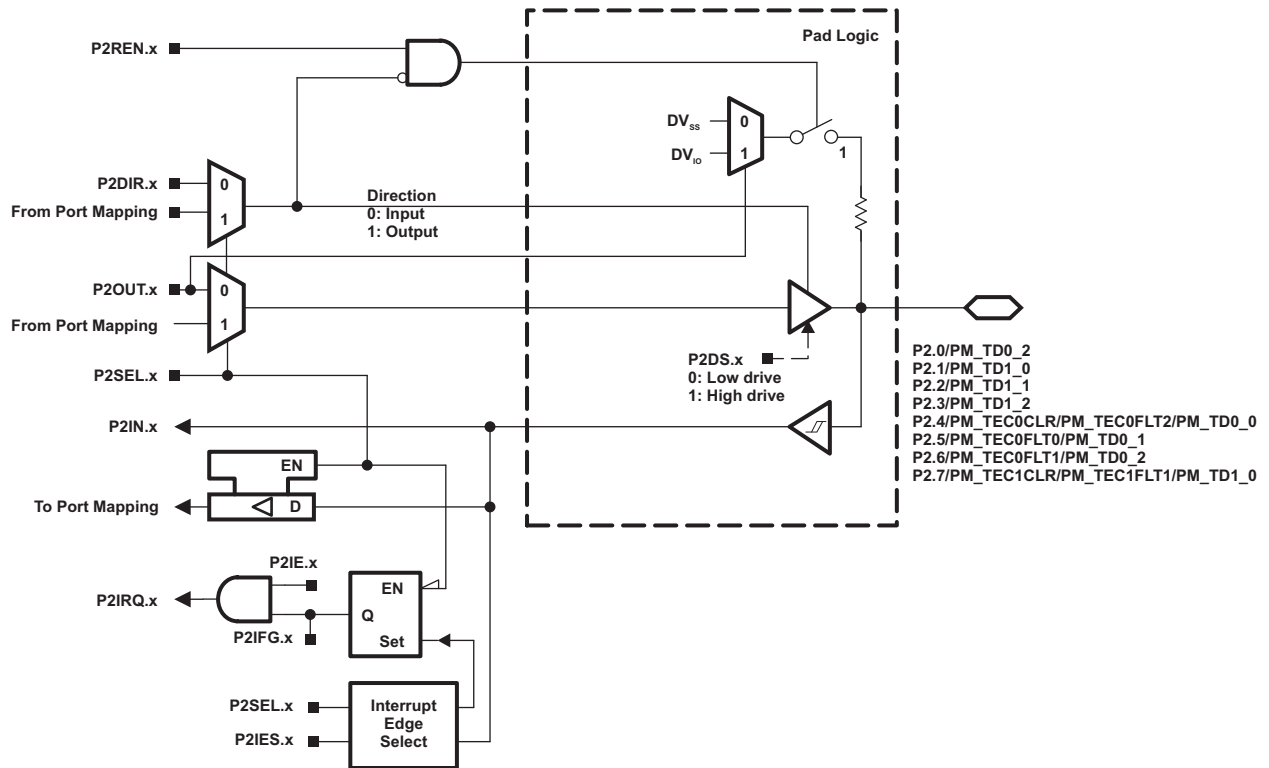

Table 47. Port P1 (P1.6 and P1.7) Pin Functions

PIN NAME (P1.x)	x	FUNCTION	CONTROL BITS/SIGNALS <sup>(1)</sup>		
			P1DIR.x	P1SEL.x	P1MAP.x
P1.6/ PM_TD0.0	6	P1.x (I/O)	I: 0; O: 1	0	X
		TD0.CCI0A	0	1	default
		TD0.TA0	1	1	default
P1.7/ PM_TD0.1	7	P1.x (I/O)	I: 0; O: 1	0	X
		TD0.CCI1A	0	1	default
		TD0.TA1	1	1	default

(1) X = Don't care

### Port P2, P2.0 to P2.7, Input/Output With Schmitt Trigger



**Table 48. Port P2 (P2.0 to P2.7) Pin Functions**

PIN NAME (P2.x)	x	FUNCTION	CONTROL BITS/SIGNALS		
			P2DIR.x	P2SEL.x	P2MAP.x
P2.0/ PM_TD0.2	0	P2.x (I/O)	I: 0; O: 1	0	X
		TD0.CCI2A	0	1	default
		TD0.TA2	1	1	default
P2.1/ PM_TD1.0	1	P2.x (I/O)	I: 0; O: 1	0	X
		TD1.CCI0A	0	1	default
		TD1.TA0	1	1	default
P2.2/ PM_TD1.1	2	P2.x (I/O)	I: 0; O: 1	0	X
		TD1.CCI1A	0	1	default
		TD1.TA1	1	1	default
P2.3/ PM_TD1.2	3	P2.x (I/O)	I: 0; O: 1	0	0
		TD1.CCI2A	0	1	default
		TD1.TA2	1	1	default
P2.4/ PM_TEC0CLR/ PM_TEC0FLT2/ PM_TD0.0	4	P2.x (I/O)	I: 0; O: 1	0	X
		TD0.TECEXTCLR, controlled by enable signals in the TEC0 module	0	1	default
		TD0.TECXFLT2, controlled by enable signals in the TEC0 module	0	1	default
		TD0.TA0	1	1	default
P2.5/ PM_TEC0FLT0/ PM_TD0.1	5	P2.x (I/O)	I: 0; O: 1	0	x
		TD0.TECXFLT0, controlled by enable signals in the TEC0 module	0	1	default
		TD0.TA1	1	1	default
P2.6/ PM_TEC0FLT1/ PM_TD0.2	6	P2.x (I/O)	I: 0; O: 1	0	X
		TD0.TECXFLT1, controlled by enable signals in the TEC0 module	0	1	default
		TD0.TA2	1	1	default
P2.7/ PM_TEC1CLR/ PM_TEC1FLT1/ PM_TD1.0	7	P2.x (I/O)	I: 0; O: 1	0	X
		TD1.TECEXTCLR, controlled by enable signals in the TEC1 module	0	1	default
		TD1.TECXFLT1, controlled by enable signals in the TEC1 module	0	1	default
		TD1.TA0	1	1	default

**Port P3, P3.0 and P3.1, Input/Output With Schmitt Trigger**

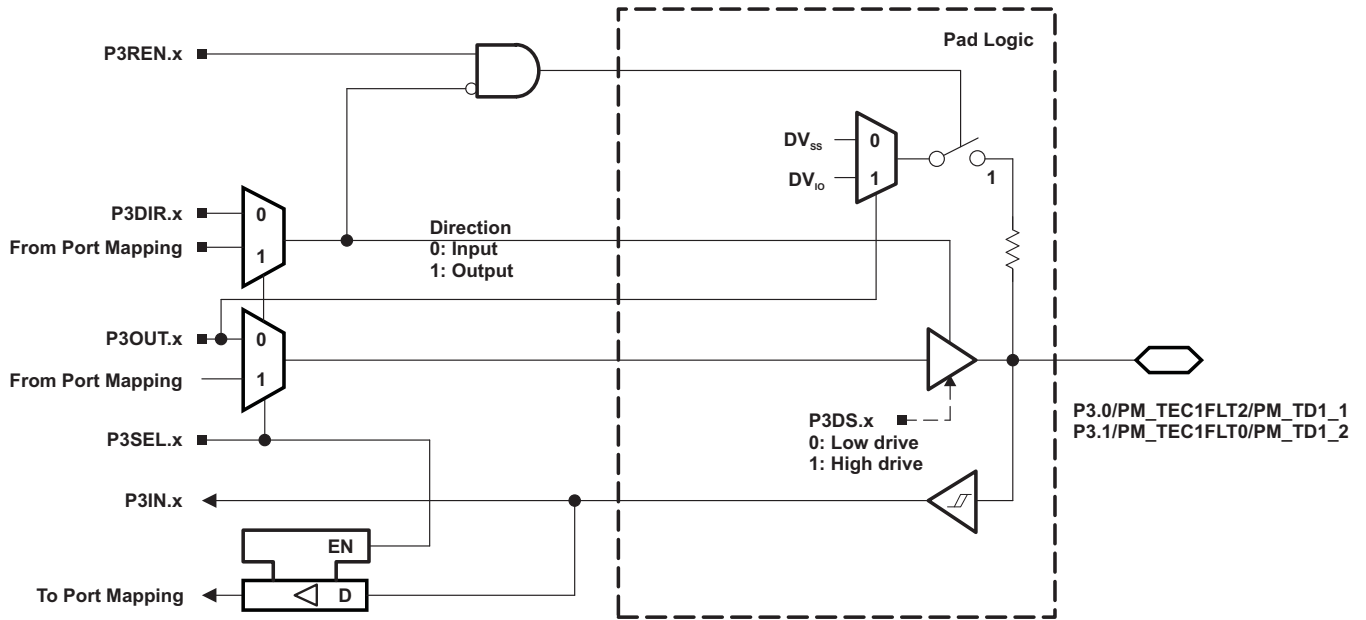

**Table 49. Port P3 (P3.0 and P3.1) Pin Functions**

PIN NAME (P3.x)	x	FUNCTION	CONTROL BITS/SIGNALS		
			P3DIR.x	P3SEL.x	P3MAP.x
P3.0/ PM_TEC1FLT2/ PM_TD1.1	0	P3.x (I/O)	I: 0; O: 1	0	X
		TD1.TECXFLT2, controlled by enable signals in the TEC1 module	0	1	default
		TD1.TA1	1	1	default
P3.1/ PM_TEC1FLT0/ PM_TD1.2	1	P3.x (I/O)	I: 0; O: 1	0	X
		TD1.TECXFLT0, controlled by enable signals in the TEC1 module	0	1	default
		TD1.TA2	1	1	default

Port P3, P3.2 and P3.3, Input/Output With Schmitt Trigger

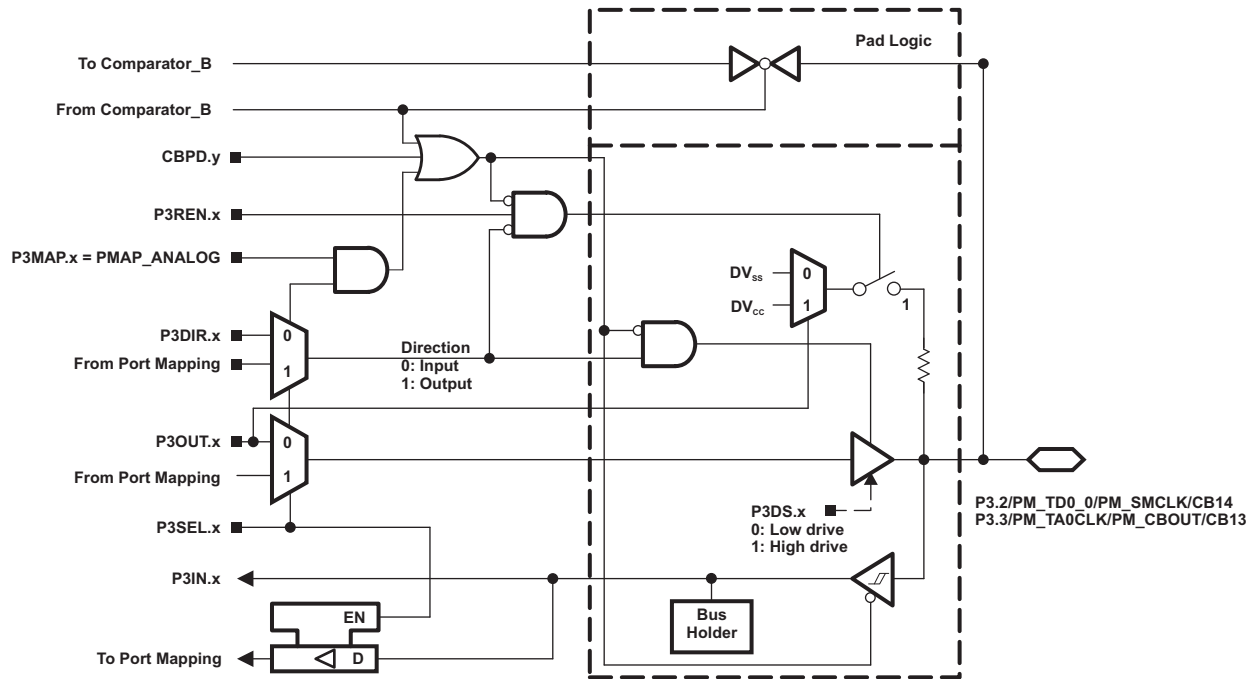
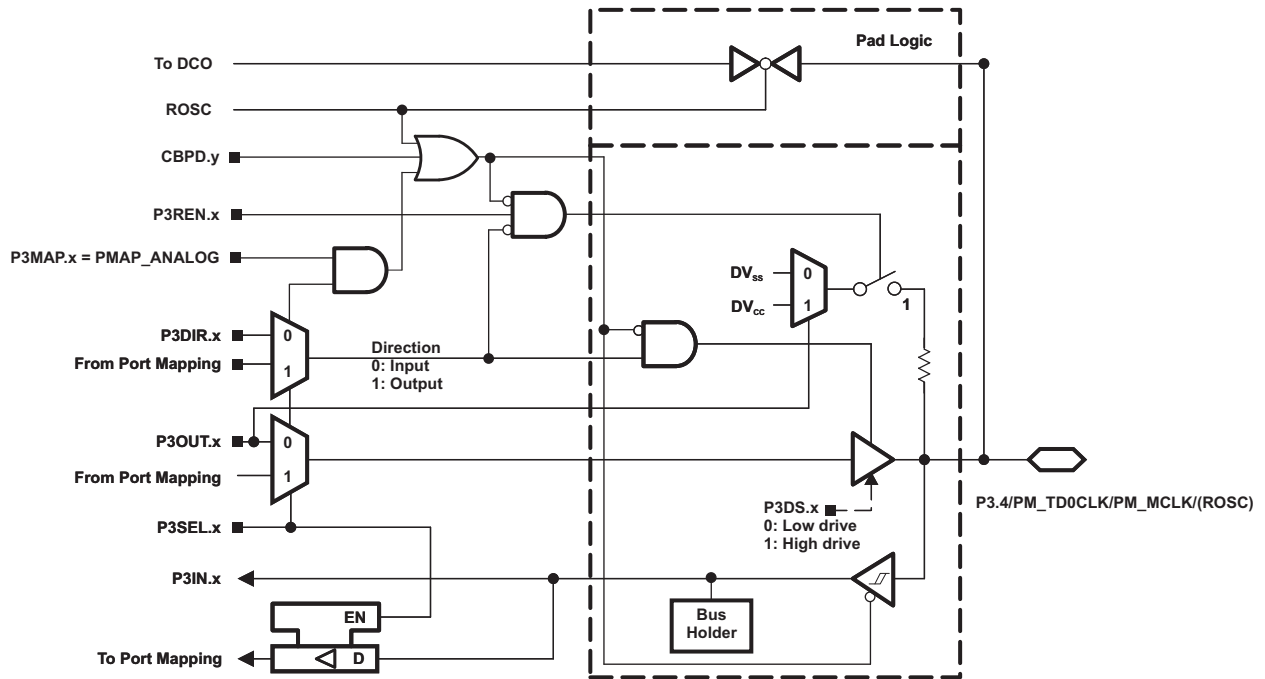

Table 50. Port P3 (P3.2 and P3.3) Pin Functions

PIN NAME (P3.x)	x	FUNCTION	CONTROL BITS/SIGNALS <sup>(1)</sup>			
			P3DIR.x	P3SEL.x	P3MAP.x	CBPD.y
P3.2/ PM_TD0.0/ PM_SMCLK/ CB14	2	P3.x (I/O)	I: 0; O: 1	0	X	0
		TD0.CCI0A	0	1	default	0
		SMCLK output	1	1	default	0
		CB14	X	X	X	1 (y = 14)
P3.3/ PM_TA0CLK/ PM_CBOUT/ CB13	3	P3.x (I/O)	I: 0; O: 1	0	X	0
		TA0.TA0CLK	0	1	default	0
		CBOUT	1	1	default	0
		CB13	X	X	X	1 (y = 13)

(1) X = Don't care

### Port P3, P3.4, Input/Output With Schmitt Trigger



**Table 51. Port P3 (P3.4) Pin Functions**

PIN NAME (P3.x)	x	FUNCTION	CONTROL BITS/SIGNALS <sup>(1)</sup>			
			P3DIR.x	P3SEL.x	P3MAP.x	
P3.4/	4	P3.x (I/O)	I: 0; O: 1	0	X	0
PM_TD0CLK/		TD0 clock input	0	1	default	0
PM_MCLK		MCLK output	1	1	default	0

(1) X = Don't care

### Port P3, P3.5, Input/Output With Schmitt Trigger

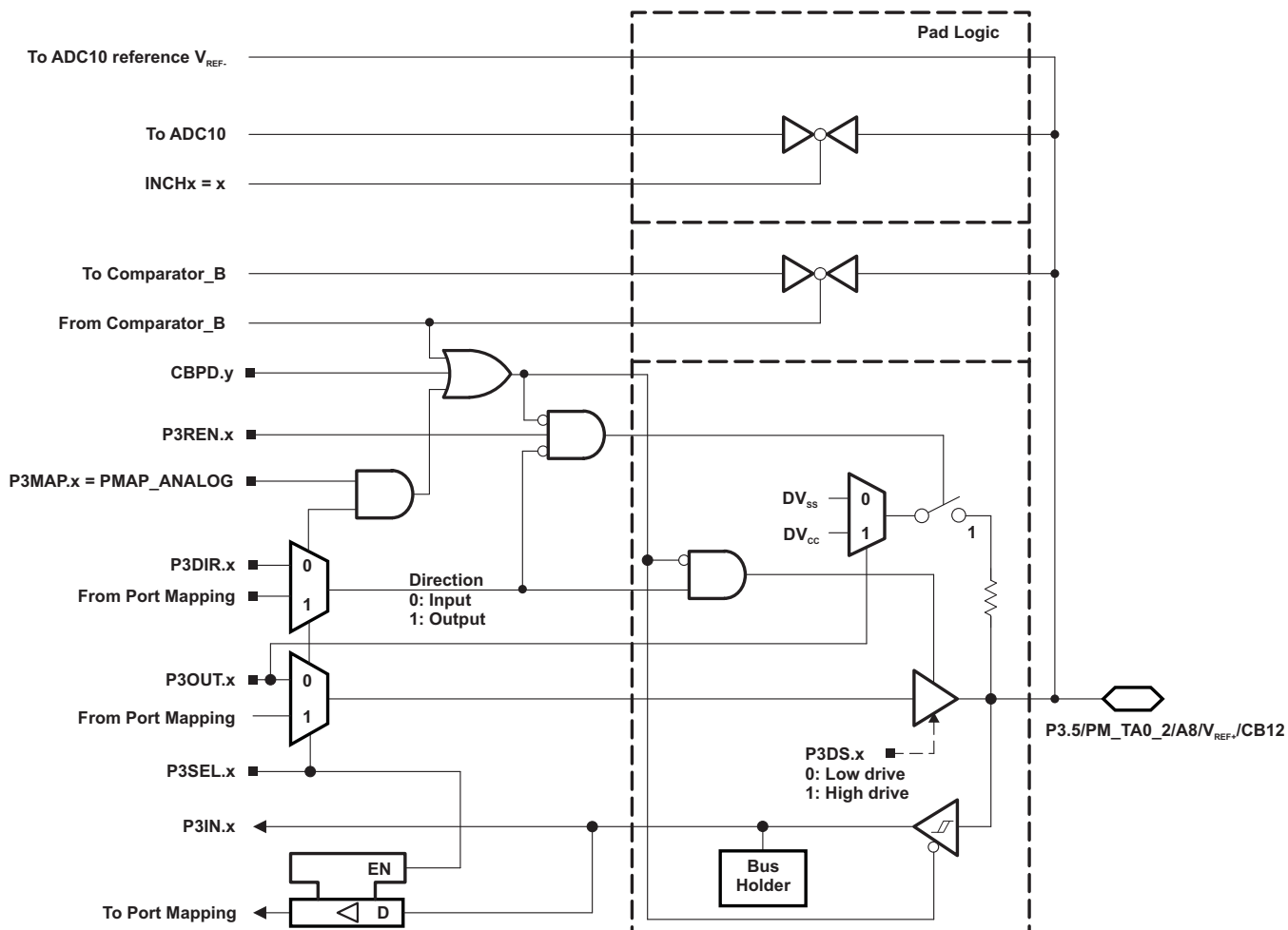

Table 52. Port P3 (P3.5) Pin Functions

PIN NAME (P3.x)	x	FUNCTION	CONTROL BITS/SIGNALS <sup>(1)</sup>			
			P3DIR.x	P3SEL.x	P3MAP.x	CBPD.y
P3.5/ PM_TA0.2/	5	P3.x (I/O)	I: 0; O: 1	0	X	0
		TA0.CCI2A	0	1	default	0
		TA0.TA2	1	1	default	0
VEREF+/ A8/ CB12		VEREF+ <sup>(2)</sup>	X	1	31	X
		A8 <sup>(2)</sup>	X	1	INCHx=8	X
		CB12	X	X	X	1 (y = 12)

(1) X = Don't care  
(2) MSP430F51x2 devices only.

### Port P3, P3.6, Input/Output With Schmitt Trigger

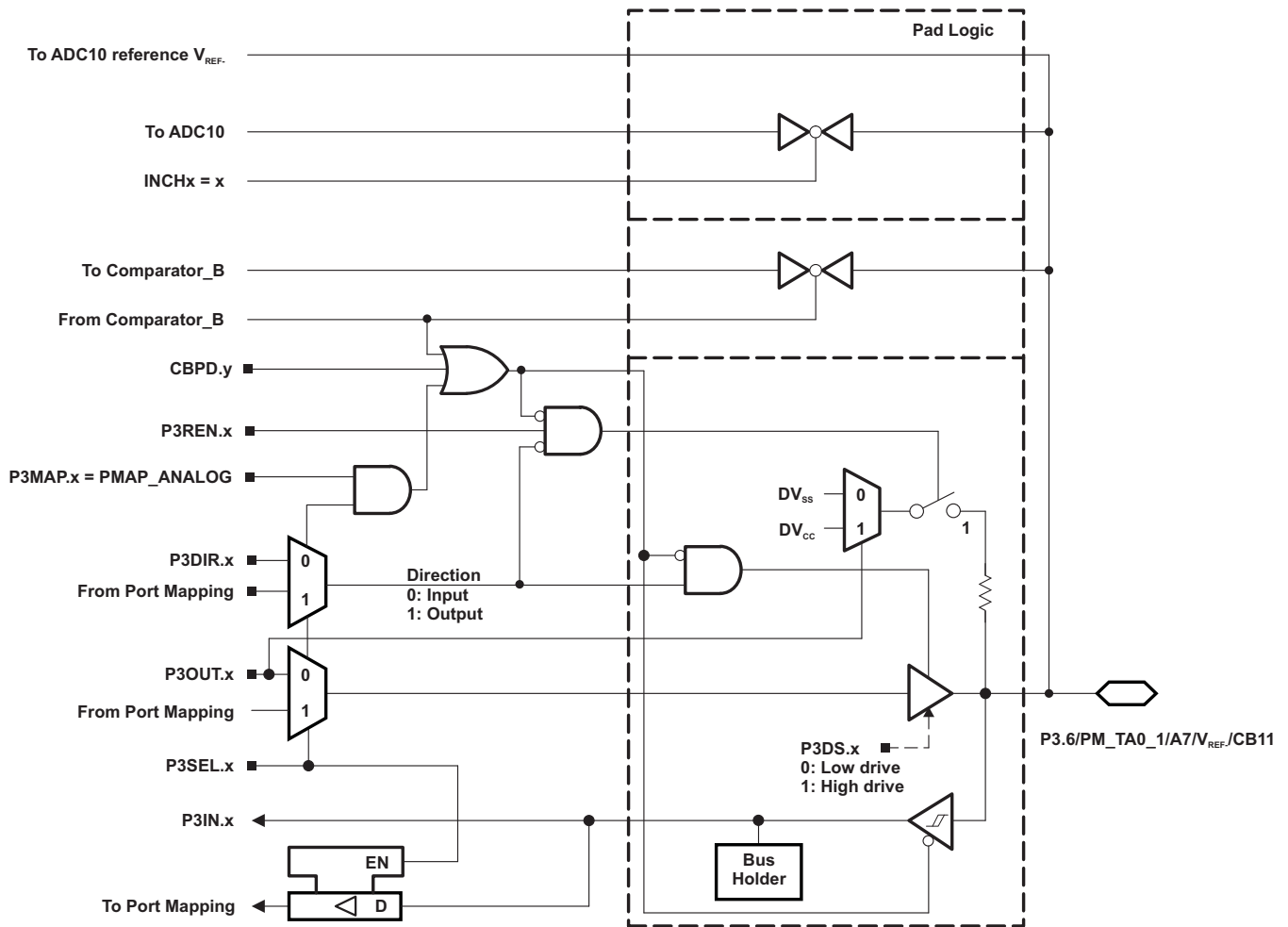

Table 53. Port P3 (P3.6) Pin Functions

PIN NAME (P3.x)	x	FUNCTION	CONTROL BITS/SIGNALS <sup>(1)</sup>			
			P3DIR.x	P3SEL.x	P3MAP.x	CBPD.y
P3.6/ PM_TA0.1/	6	P3.x (I/O) <sup>(2)</sup>	I: 0; O: 1	0	X	0
		TA0.CCR0	0	1	default	0
		TA0.TA1	1	1	default	0
VEREF-/		VEREF- <sup>(3)</sup>	X	1	31	X
A7/		A7 <sup>(3)</sup>	X	1	31 INCHx = 7	X
CB11		CB11	X	X	0	1 (y = 11)

(1) X = Don't care  
(2) Default condition.  
(3) MSP430F51x2 devices only.

Port P3, P3.7, Input/Output With Schmitt Trigger

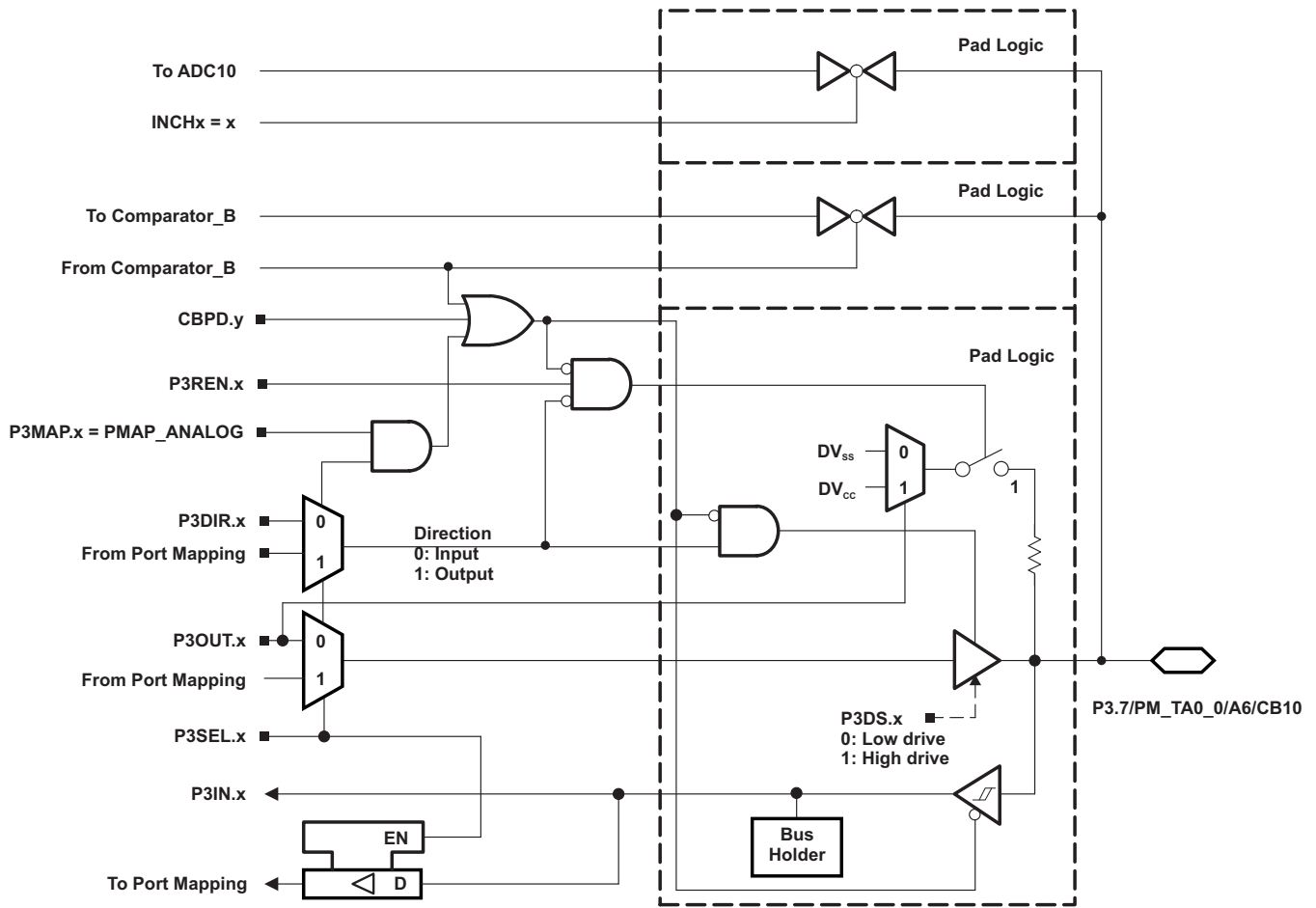

Table 54. Port P3 (P3.7) Pin Functions

PIN NAME (P3.x)	x	FUNCTION	CONTROL BITS/SIGNALS <sup>(1)</sup>			
			P3DIR.x	P3SEL.2	P3MAP.x	CBPD.y
P3.7/ PM_TA0.0/	7	P3.x (I/O) <sup>(1)</sup>	I: 0; O: 1	0	X	0
		TA0.CCR0	0	1	default	0
		TA0.TA0	1	1	default	0
A6/		A6 <sup>(2)</sup>	X	1	31 INCHx = 6	X
CB10		CB10	X	X	0	1 (y = 10)

(1) X = Don't care

(2) MSP430F51x2 devices only.

Port J, J.0 JTAG pin TDO, Input/Output With Schmitt Trigger or Output

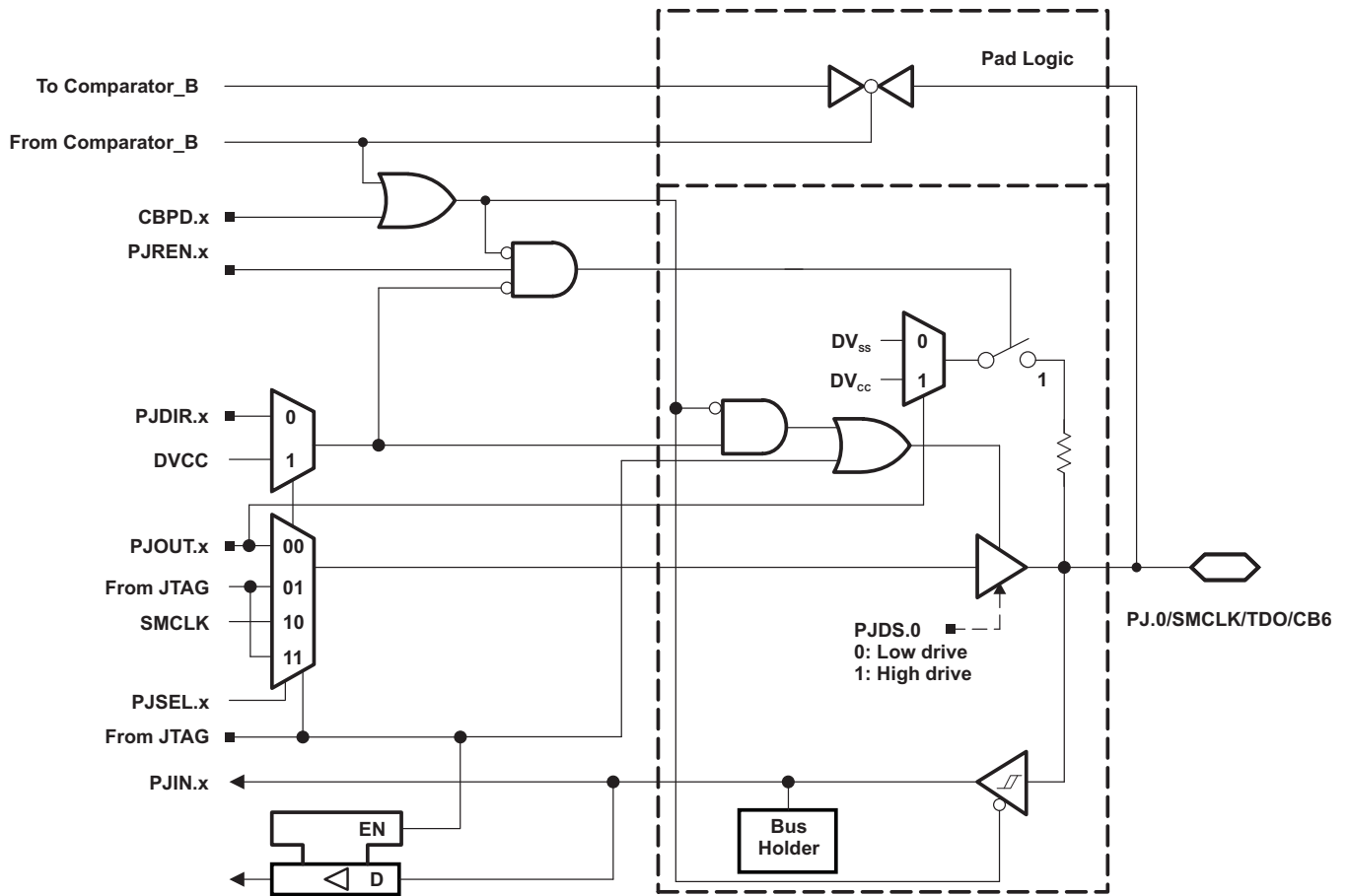

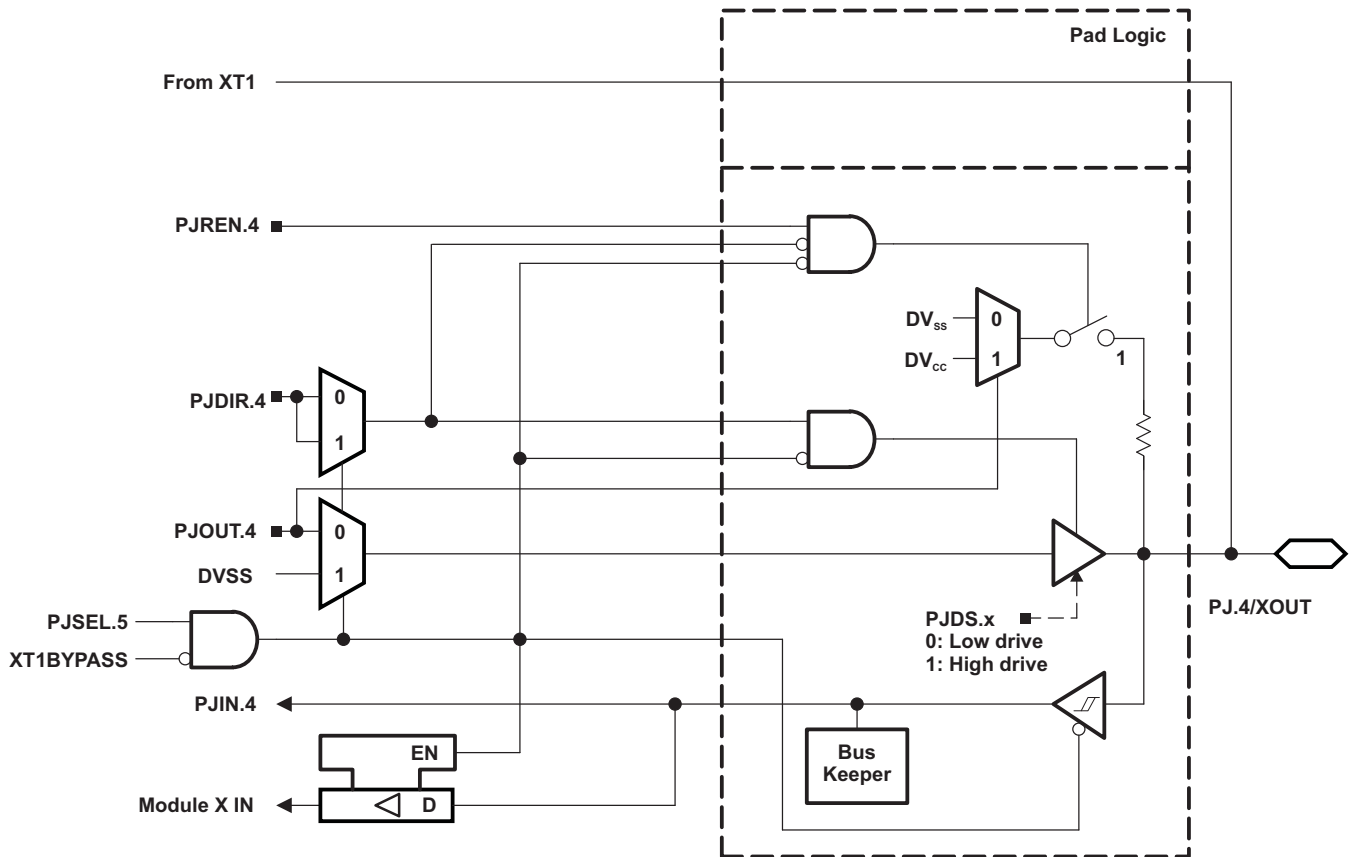

**Table 55. Port PJ (PJ.0 to PJ.3) Pin Functions**

PIN NAME (PJ.x)	x	FUNCTION	CONTROL BITS/ SIGNALS <sup>(1)</sup>			
			PJDIR.x	PJSEL.x	JTAG MODE	CBPD.y
PJ.0/ SMCLK/ TDO/ CB6	0	PJ.x (I/O) <sup>(2)</sup>	I: 0; O: 1	0	0	0
		SMCLK	1	1	0	0
		TDO <sup>(3)</sup>	X	X	1	X
		CB6	X	X	0	1 (y = 6)
PJ.1/ MCLK/ TDI/TCLK/ CB7	1	PJ.x (I/O) <sup>(2)</sup>	I: 0; O: 1	0	0	0
		MCLK	1	1	0	0
		TDI/TCLK <sup>(3) (4)</sup>	X	X	1	X
		CB7	0	X	0	1 (y = 7)
PJ.2/ ADC10CLK/ TMS/ CB8	2	PJ.x (I/O) <sup>(2)</sup>	I: 0; O: 1	0	0	0
		ADC10CLK (See <sup>(5)</sup> )	1	1	0	0
		TMS <sup>(3) (4)</sup>	X	X	1	X
		CB8	X	X	0	1 (y = 8)
PJ.3/ ACLK/ TCK/ CB9	3	PJ.x (I/O) <sup>(2)</sup>	I: 0; O: 1	0	0	0
		ACLK	1	1	0	0
		TCK <sup>(3) (4)</sup>	X	X	1	X
		CB9	X	X	0	1 (y = 9)

- (1) X = Don't care
- (2) Default condition
- (3) The pin direction is controlled by the JTAG module.
- (4) In JTAG mode, pullups are activated automatically on TMS, TCK, and TDI/TCLK. PJREN.x are do not care.
- (5) MSP430F51x2 device only.

### Port PJ.4, Input/Output With Schmitt Trigger



Port PJ.5, Input/Output With Schmitt Trigger

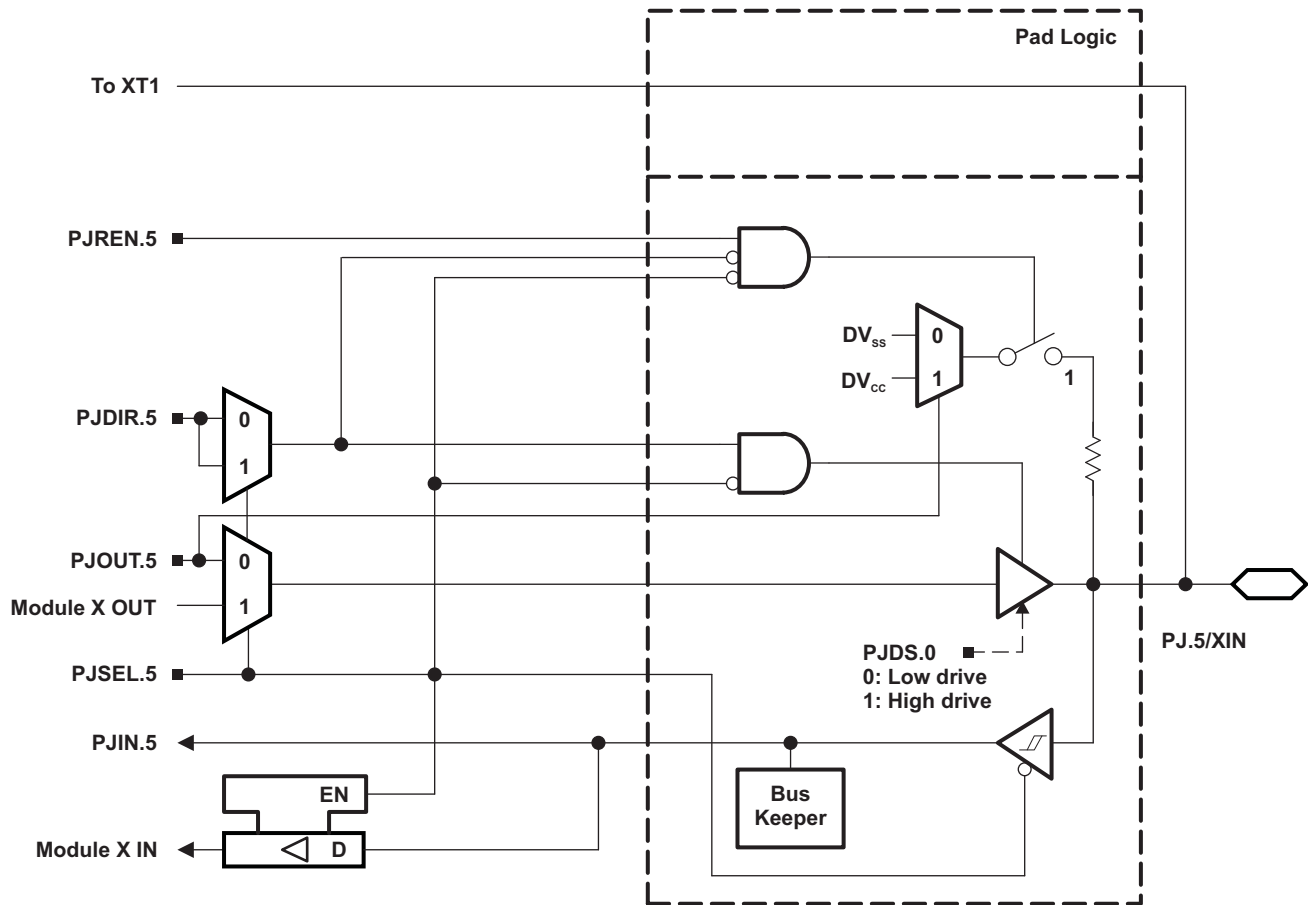

Table 56. Port PJ (PJ.4 and PJ.5) Pin Functions

PIN NAME (PJ.x)	x	FUNCTION	CONTROL BITS/SIGNALS <sup>(1)</sup>			
			PJDIR.x	PJSEL.4	PJSEL.5	XT1BYPAS S
PJ.4/	4	PJ.x (I/O)	I: 0; O: 1	X	0	x
XOUT		XOUT crystal mode <sup>(2)</sup>	X	X	1	0
PJ.5/	5	PJ.x (I/O) <sup>(3)</sup>	I: 0; O: 1	X	0	x
XIN		XIN crystal mode <sup>(4)</sup>	X	X	1	0
		XIN bypass mode <sup>(4)</sup>	X	X	1	1

- (1) X = Don't care
- (2) Setting PJSEL.5 causes the general-purpose I/O to be disabled in crystal mode. When using bypass mode, PJ.4 can be used as general-purpose I/O.
- (3) Setting PJSEL.5 causes the general-purpose I/O to be disabled in crystal mode. When using bypass mode, PJ.4 can be used as general-purpose I/O.
- (4) Setting PJSEL.5 causes the general-purpose I/O to be disabled. Pending the setting of XT1BYPASS, PJ.5 is configured for crystal mode or bypass mode.

### Port PJ.6, Input/Output With Schmitt Trigger

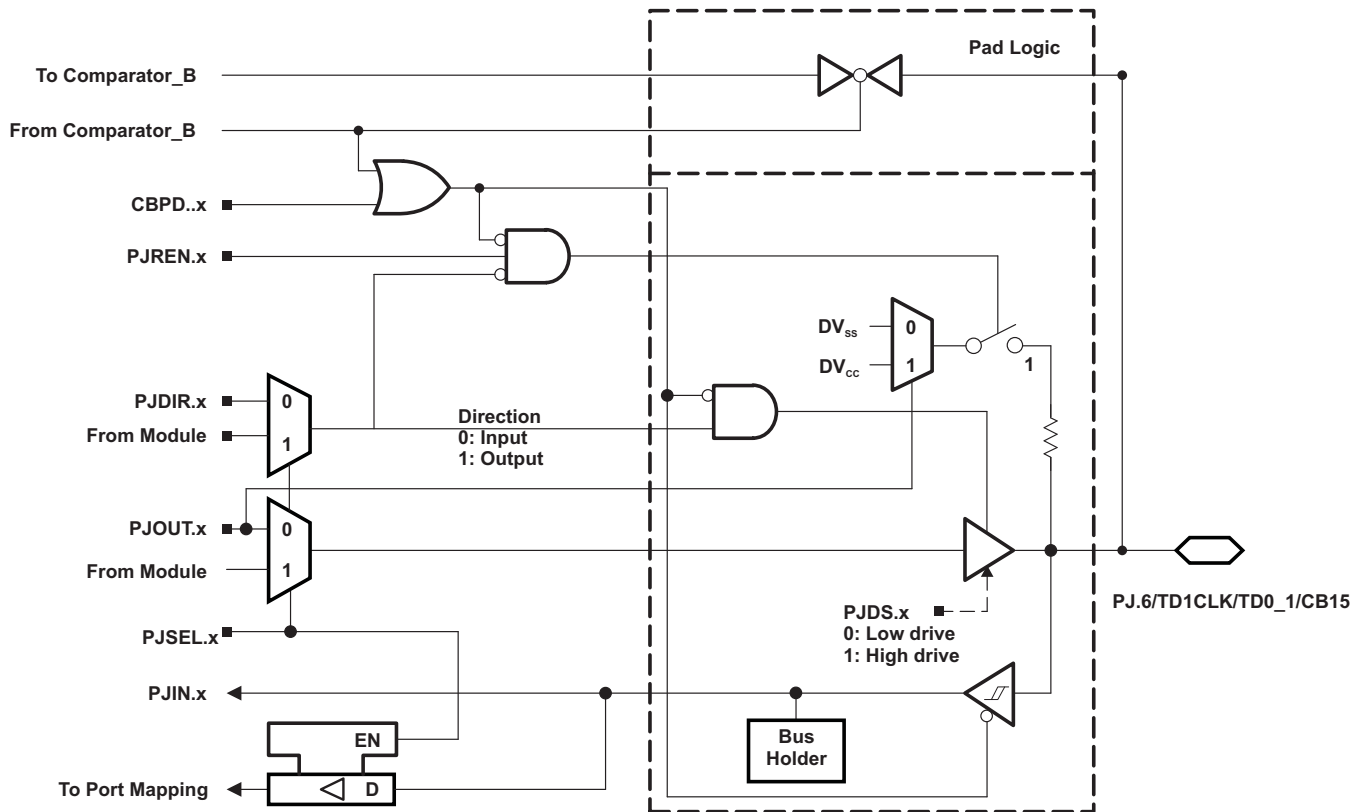

Table 57. Port PJ (PJ.6) Pin Functions

PIN NAME (PJ.x)	x	FUNCTION	CONTROL BITS/SIGNALS <sup>(1)</sup>		
			PJDIR.x	PJSEL.x	CBPD.y
PJ.6/	6	PJ.x (I/O)	I: 0; O: 1	0	0
TD1CLK/		TD1 clock input	0	1	0
TD0.1/		TD0.TA1	1	1	0
CB15		CB15	X	X	1 (y = 15)

(1) X = Don't care

## DEVICE DESCRIPTORS

Table 58 list the complete contents of the device descriptor tag-length-value (TLV) structure for each device type.

**Table 58. 'F51x2 Device Descriptor Table<sup>(1)</sup>**

	Description	Address	Size bytes	'F5172 RSB	'F5172 DA	'F5152 RSB	'F5152 DA	'F5132 RSB	'F5132 DA
				Value	Value	Value	Value	Value	Value
<b>Info Block</b>	Info length	0x1A00	1	0x06	0x06	0x06	0x06	0x06	0x06
	CRC length	0x1A01	1	0x06	0x06	0x06	0x06	0x06	0x06
	CRC value	0x1A02	2	per unit	per unit	per unit	per unit	per unit	per unit
	Device ID	0x1A04	1	0x30	0x30	0x2C	0x2C	0x28	0x28
	Device ID	0x1A05	1	0x80	0x80	0x80	0x80	0x80	0x80
	Hardware revision	0x1A06	1	0x30	030	0x30	0x30	0x30	0x30
	Firmware revision	0x1A07	1	0x10	0x10	0x10	0x10	0x10	0x10
<b>Die Record</b>	Die Record Tag	0x1A08	1	0x08	08	0x08	08	0x08	08
	Die Record length	0x1A09	1	0x0A	0A	0x0A	0A	0x0A	0A
	Lot/Wafer ID	0x1A0A	4	per unit	per unit	per unit	per unit	per unit	per unit
	Die X position	0x1A0Eh	2	per unit	per unit	per unit	per unit	per unit	per unit
	Die Y position	0x1A10	2	per unit	per unit	per unit	per unit	per unit	per unit
	Test results	0x1A12	2	per unit	per unit	per unit	per unit	per unit	per unit
<b>ADC10 Calibration</b>	ADC10 Calibration Tag	0x1A14	1	0x13	0x13	0x13	0x13	0x13	0x13
	ADC10 Calibration length	0x1A15	1	0x10	0x10	0x10	0x10	0x10	0x10
	ADC Gain Factor	0x1A16	2	per unit	per unit	per unit	per unit	per unit	per unit
	ADC Offset	0x1A18	2	per unit	per unit	per unit	per unit	per unit	per unit
	ADC 1.5-V Reference Temp. Sensor 30°C	0x1A1A	2	per unit	per unit	per unit	per unit	per unit	per unit
	ADC 1.5-V Reference Temp. Sensor 85°C	0x1A1C	2	per unit	per unit	per unit	per unit	per unit	per unit
	ADC 2.0-V Reference Temp. Sensor 30°C	0x1A1Eh	2	per unit	per unit	per unit	per unit	per unit	per unit
	ADC 2.0-V Reference Temp. Sensor 85°C	0x1A20	2	per unit	per unit	per unit	per unit	per unit	per unit
	ADC 2.5-V Reference Temp. Sensor 30°C	0x1A22	2	per unit	per unit	per unit	per unit	per unit	per unit
	ADC 2.5-V Reference Temp. Sensor 85°C	0x1A24	2	per unit	per unit	per unit	per unit	per unit	per unit
<b>REF User Calibration</b>	REF Tag	0x1A26	1	0x12	0x12	0x12	0x12	0x12	0x12
	REF length	0x1A27	1	0x06	0x06	0x06	0x06	0x06	0x06
	REF 1.5-V Reference	0x1A28	2	0xFF	0xFF	0xFF	0xFF	0xFF	0xFF
	REF 2.0-V Reference	0x1A2A	2	0xFF	0xFF	0xFF	0xFF	0xFF	0xFF
	REF 2.5-V Reference	0x1A2C	2	0xFF	0xFF	0xFF	0xFF	0xFF	0xFF
<b>Timer_D0 Calibration</b>	Timer_D Tag	0x1A2E	1	0x15	0x15	0x15	0x15	0x15	0x15
	Timer_D length	0x1A30	1	0x08	0x08	0x08	0x08	0x08	0x08
	Timer_D 64-MHz frequency	0x1A31	2	per unit	per unit	per unit	per unit	per unit	per unit
	Timer_D 128-MHz frequency	0x1A32	2	per unit	per unit	per unit	per unit	per unit	per unit
	Timer_D 200-MHz frequency	0x1A34	2	per unit	per unit	per unit	per unit	per unit	per unit
<b>Timer_D1 Calibration</b>	Timer_D 256-MHz frequency	0x1A36	2	per unit	per unit	per unit	per unit	per unit	per unit
	Timer_D Tag	0x1A38	1	0x15	0x15	0x15	0x15	0x15	0x15
	Timer_D length	0x1A39	1	0x08	0x08	0x08	0x08	0x08	0x08
	Timer_D 64-MHz frequency	0x1A3A	2	per unit	per unit	per unit	per unit	per unit	per unit
	Timer_D 128-MHz frequency	0x1A3C	2	per unit	per unit	per unit	per unit	per unit	per unit

(1) NA = Not applicable

**Table 58. 'F51x2 Device Descriptor Table<sup>(1)</sup> (continued)**

	Description	Address	Size bytes	'F5172 RSB	'F5172 DA	'F5152 RSB	'F5152 DA	'F5132 RSB	'F5132 DA
				Value	Value	Value	Value	Value	Value
	Timer_D 200-MHz frequency	0x1A3E	2	per unit	per unit	per unit	per unit	per unit	per unit
	Timer_D 256-MHz frequency	0x1A40	2	per unit	per unit	per unit	per unit	per unit	per unit
<b>Peripheral Descriptor</b>	Peripheral Descriptor Tag	0x1A42	1	0x02	0x02	0x02	0x02	0x02	0x02
	Peripheral Descriptor Length	0x1A43	1	0x53	0x53	0x53	0x53	0x53	0x53
	BSL Memory	0x1A44	2	0x8A08	0x8A08	0x8A08	0x8A08	0x8A08	0x8A08
	Information Memory	0x1A46	2	0x860C	0x860C	0x860C	0x860C	0x860C	0x860C
	RAM	0x1A48	2	0x2A0E	0x2A0E	0x2A0E	0x2A0E	0x280E	0x280E
	Main Memory	0x1A4A	2	0x9240	0x9240	0x9060	0x9060	0x8E70	0x8E70
	Delimiter	0x1A4C	1	0x00	0x00	0x00	0x00	0x00	0x00
	Peripheral count	0x1A4D	1	0x1C	0x1C	0x1B	0x1B	0x1B	0x1B
	MSP430CPUXV2	0x1A4E	2	0x2300	0x2300	0x2300	0x2300	0x2300	0x2300
	SBW	0x1A50	2	0x0F00	0x0F00	0x0F00	0x0F00	0x0F00	0x0F00
	EEM-S	0x1A52	2	0x0300	0x0300	0x0300	0x0300	0x0300	0x0300
	TI BSL	0x1A54	2	0xFC00	0xFC00	0xFC00	0xFC00	0xFC00	0xFC00
	SFR	0x1A56	2	0x4110	0x4110	0x4110	0x4110	0x4110	0x4110
	PMM	0x1A58	2	0x3002	0x3002	0x3002	0x3002	0x3002	0x3002
	FCTL	0x1A5A	2	0x3802	0x3802	0x3802	0x3802	0x3802	0x3802
	CRC16	0x1A5C	2	0x3C01	0x3C01	0x3C01	0x3C01	0x3C01	0x3C01
	CRC16_RB	0x1A5E	2	0x3D00	0x3D00	0x3D00	0x3D00	0x3D00	0x3D00
	RAMCTL	0x1A60	2	0x4400	0x4400	0x4400	0x4400	0x4400	0x4400
	WDT_A	0x1A62	2	0x4000	0x4000	0x4000	0x4000	0x4000	0x4000
	UCS	0x1A64	2	0x4801	0x4801	0x4801	0x4801	0x4801	0x4801
	SYS	0x1A66	2	0x4202	0x4202	0x4202	0x4202	0x4202	0x4202
	Shared REF	0x1A68	2	0xA003	0xA003	0xA003	0xA003	0xA003	0xA003
	Port Mapping	0x1A6A	2	0x1001	0x1001	0x1001	0x1001	0x1001	0x1001
	Port 1/2	0x1A6C	2	0x5104	0x5104	0x5104	0x5104	0x5104	0x5104
	Port 3/4	0x1A6E	2	0x5202	0x5202	0x5202	0x5202	0x5202	0x5202
	Port J	0x1A70	2	0x5F10	0x5F10	0x5F10	0x5F10	0x5F10	0x5F10
	TA0	0x1A72	2	0x610A	0x610A	0x610A	0x610A	0x610A	0x610A
	MPY32	0x1A74	2	0x8510	0x8510	0x8510	0x8510	0x8510	0x8510
	DMA with 3 channels	0x1A76	2	0x4704	0x4704	0x4704	0x4704	0x4704	0x4704
	USCI_A0/B0	0x1A78	2	0x900C	0x900C	0x900C	0x900C	0x900C	0x900C
	ADC10_A	0x1A7A	2	0xD318	0xD318	0xD318	0xD318	0xD318	0xD318
	COMP_B	0x1A7C	2	0xA818	0xA818	0x1A919	0xA818	0x1A919	0xA818
	TIMER_D0	0x1A7E	2	0xD624	0xD624	0xD624	0xD624	0xD624	0xD624
	TIMER_D1	0x1A80	2	0x6D04	0x6D04	0x6D04	0x6D04	0x6D04	0x6D04
	TEC_0	0x1A82	2	0x700C	0x700C	0x700C	0x700C	0x700C	0x700C
	TEC_1	0x1A84	2	0x7002	0x7002	0x7002	0x7002	0x7002	0x7002
<b>Interrupts</b>	COMP_B	0x1A86	1	0xA8	0xA8	0xA8	0xA8	0xA8	0xA8
	TEC_0	0x1A87	1	0x6D	0x6D	0x6D	0x6D	0x6D	0x6D
	TIMER_D0	0x1A88	1	0x62	0x62	0x62	0x62	0x62	0x62
	TIMER_D0	0x1A89	1	0x63	0x63	0x63	0x63	0x63	0x63
	WDTIFG	0x1A8A	1	0x40	0x40	0x40	0x40	0x40	0x40
	USCI_A0	0x1A8B	1	0x90	0x90	0x90	0x90	0x90	0x90
	USCI_B0	0x1A8C	1	0x91	0x91	0x91	0x91	0x91	0x91
	ADC10_A	0x1A8D	1	0xD0	0xD0	0xD0	0xD0	0xD0	0xD0
	TA0.CCIFG0	0x1A8E	1	0x60	0x60	0x60	0x60	0x60	0x60
	TA0.CCIFG1..4	0x1A8F	1	0x61	0x61	0x61	0x61	0x61	0x61
	DMA	0x1A90	1	0x46	0x46	0x46	0x46	0x46	0x46

**Table 58. 'F51x2 Device Descriptor Table<sup>(1)</sup> (continued)**

	Description	Address	Size bytes	'F5172 RSB	'F5172 DA	'F5152 RSB	'F5152 DA	'F5132 RSB	'F5132 DA
				Value	Value	Value	Value	Value	Value
	TEC_1	0x1A91	1	0x6E	0x6E	0x6E	0x6E	0x6E	0x6E
	TIMER_D1	0x1A92	1	0x64	0x64	0x64	0x64	0x64	0x64
	TIMER_D1	0x1A93	1	0x65	0x65	0x65	0x65	0x65	0x65
	Port P1	0x1A94	1	0x50	0x50	0x50	0x50	0x50	0x50
	Port P2	0x1A95	1	0x51	0x51	0x51	0x51	0x51	0x51
	delimiter	0x1A96	1	0x00	0x00	0x00	0x00	0x00	0x00
<b>Empty</b>	Unused Memory	0x1A97 - 0x1AB9		0xFF	0xFF	0xFF	0xFF	0xFF	0xFF

**Table 59. 'F51x1 Device Descriptor Table<sup>(1)</sup>**

	Description	Address	Size bytes	'F5171 RSB	'F5171 DA	'F5151 RSB	'F5151 DA	'F5131 RSB	'F5131 DA
				Value	Value	Value	Value	Value	Value
<b>Info Block</b>	Info length	0x1A00	1	0x06	0x06	0x06	0x06	0x06	0x06
	CRC length	0x1A01	1	0x06	0x06	0x06	0x06	0x06	0x06
	CRC value	0x1A02	2	per unit	per unit	per unit	per unit	per unit	per unit
	Device ID	0x1A04	1	0x2E	0x2E	0x2A	0x2A	0x26	0x26
	Device ID	0x1A05	1	0x80	0x80	0x80	0x80	0x80	0x80
	Hardware revision	0x1A06	1	0x30	0x30	0x30	0x30	0x30	0x30
	Firmware revision	0x1A07	1	0x10	0x10	0x10	0x10	0x10	0x10
<b>Die Record</b>	Die Record Tag	0x1A08	1	0x08	08	0x08	08	0x08	08
	Die Record length	0x1A09	1	0x0A	0A	0x0A	0A	0x0A	0A
	Lot/Wafer ID	0x1A0A	4	per unit	per unit	per unit	per unit	per unit	per unit
	Die X position	0x1A0Eh	2	per unit	per unit	per unit	per unit	per unit	per unit
	Die Y position	0x1A10	2	per unit	per unit	per unit	per unit	per unit	per unit
	Test results	0x1A12	2	per unit	per unit	per unit	per unit	per unit	per unit
<b>ADC10 Calibration</b>	ADC10 Calibration Tag	0x1A14	1	0x05	0x05	0x05	0x05	0x05	0x05
	ADC10 Calibration length	0x1A15	1	0x10	0x10	0x10	0x10	0x10	0x10
	ADC Gain Factor	0x1A16	2	per unit	per unit	per unit	per unit	per unit	per unit
	ADC Offset	0x1A18	2	per unit	per unit	per unit	per unit	per unit	per unit
	ADC 1.5-V Reference Temp. Sensor 30°C	0x1A1A	2	per unit	per unit	per unit	per unit	per unit	per unit
	ADC 1.5-V Reference Temp. Sensor 85°C	0x1A1C	2	per unit	per unit	per unit	per unit	per unit	per unit
	ADC 2.0-V Reference Temp. Sensor 30°C	0x1A1Eh	2	per unit	per unit	per unit	per unit	per unit	per unit
	ADC 2.0-V Reference Temp. Sensor 85°C	0x1A20	2	per unit	per unit	per unit	per unit	per unit	per unit
	ADC 2.5-V Reference Temp. Sensor 30°C	0x1A22	2	per unit	per unit	per unit	per unit	per unit	per unit
	ADC 2.5-V Reference Temp. Sensor 85°C	0x1A24	2	per unit	per unit	per unit	per unit	per unit	per unit
<b>REF User Calibration</b>	REF Tag	0x1A26	1	0x12	0x12	0x12	0x12	0x12	0x12
	REF length	0x1A27	1	0x06	0x06	0x06	0x06	0x06	0x06
	REF 1.5-V Reference	0x1A28	2	0xFF	0xFF	0xFF	0xFF	0xFF	0xFF
	REF 2.0-V Reference	0x1A2A	2	0xFF	0xFF	0xFF	0xFF	0xFF	0xFF
	REF 2.5-V Reference	0x1A2C	2	0xFF	0xFF	0xFF	0xFF	0xFF	0xFF
<b>Timer_D0 Calibration</b>	Timer_D Tag	0x1A2E	1	0x15	0x15	0x15	0x15	0x15	0x15

(1) NA = Not applicable

**Table 59. 'F51x1 Device Descriptor Table<sup>(1)</sup> (continued)**

	Description	Address	Size bytes	'F5171 RSB	'F5171 DA	'F5151 RSB	'F5151 DA	'F5131 RSB	'F5131 DA
				Value	Value	Value	Value	Value	Value
	Timer_D length	0x1A30	1	0x08	0x08	0x08	0x08	0x08	0x08
	Timer_D 64-MHz frequency	0x1A31	2	per unit	per unit	per unit	per unit	per unit	per unit
	Timer_D 128-MHz frequency	0x1A32	2	per unit	per unit	per unit	per unit	per unit	per unit
	Timer_D 200-MHz frequency	0x1A34	2	per unit	per unit	per unit	per unit	per unit	per unit
	Timer_D 256-MHz frequency	0x1A36	2	per unit	per unit	per unit	per unit	per unit	per unit
<b>Timer_D1 Calibration</b>	Timer_D Tag	0x1A38	1	0x15	0x15	0x15	0x15	0x15	0x15
	Timer_D length	0x1A39	1	0x08	0x08	0x08	0x08	0x08	0x08
	Timer_D 64-MHz frequency	0x1A3A	2	per unit	per unit	per unit	per unit	per unit	per unit
	Timer_D 128-MHz frequency	0x1A3C	2	per unit	per unit	per unit	per unit	per unit	per unit
	Timer_D 200-MHz frequency	0x1A3E	2	per unit	per unit	per unit	per unit	per unit	per unit
	Timer_D 256-MHz frequency	0x1A40	2	per unit	per unit	per unit	per unit	per unit	per unit
<b>Peripheral Descriptor</b>	Peripheral Descriptor Tag	0x1A42	1	0x02	0x02	0x02	0x02	0x02	0x02
	Peripheral Descriptor Length	0x1A43	1	0x51	0x51	0x51	0x51	0x51	0x51
	BSL Memory	0x1A44	2	0x8A08	0x8A08	0x8A08	0x8A08	0x8A08	0x8A08
	Information Memory	0x1A46	2	0x860C	0x860C	0x860C	0x860C	0x860C	0x860C
	RAM	0x1A48	2	0x2A0E	0x2A0E	0x2A0E	0x2A0E	0x280E	0x280E
	Main Memory	0x1A4A	2	0x9240	0x9240	0x9060	0x9060	0x8E70	0x8E70
	Delimiter	0x1A4C	1	0x00	0x00	0x00	0x00	0x00	0x00
	Peripheral count	0x1A4D	1	0x1B	0x1B	0x1B	0x1B	0x1B	0x1B
	MSP430CPUV2	0x1A4E	2	0x2300	0x2300	0x2300	0x2300	0x2300	0x2300
	SBW	0x1A50	2	0x0F00	0x0F00	0x0F00	0x0F00	0x0F00	0x0F00
	EEM-S	0x1A52	2	0x0300	0x0300	0x0300	0x0300	0x0300	0x0300
	TI BSL	0x1A54	2	0xFC00	0xFC00	0xFC00	0xFC00	0xFC00	0xFC00
	SFR	0x1A56	2	0x4110	0x4110	0x4110	0x4110	0x4110	0x4110
	PMM	0x1A58	2	0x3002	0x3002	0x3002	0x3002	0x3002	0x3002
	FCTL	0x1A5A	2	0x3802	0x3802	0x3802	0x3802	0x3802	0x3802
	CRC16	0x1A5C	2	0x3C01	0x3C01	0x3C01	0x3C01	0x3C01	0x3C01
	CRC16_RB	0x1A5E	2	0x3D00	0x3D00	0x3D00	0x3D00	0x3D00	0x3D00
	RAMCTL	0x1A60	2	0x4400	0x4400	0x4400	0x4400	0x4400	0x4400
	WDT_A	0x1A62	2	0x4000	0x4000	0x4000	0x4000	0x4000	0x4000
	UCS	0x1A64	2	0x4801	0x4801	0x4801	0x4801	0x4801	0x4801
	SYS	0x1A66	2	0x4202	0x4202	0x4202	0x4202	0x4202	0x4202
	Shared REF	0x1A68	2	0xA003	0xA003	0xA003	0xA003	0xA003	0xA003
	Port Mapping	0x1A6A	2	0x1001	0x1001	0x1001	0x1001	0x1001	0x1001
	Port 1/2	0x1A6C	2	0x5104	0x5104	0x5104	0x5104	0x5104	0x5104
	Port 3/4	0x1A6E	2	0x5202	0x5202	0x5202	0x5202	0x5202	0x5202
	Port J	0x1A70	2	0x5F10	0x5F10	0x5F10	0x5F10	0x5F10	0x5F10
	TA0	0x1A72	2	0x610A	0x610A	0x610A	0x610A	0x610A	0x610A
	MPY32	0x1A74	2	0x8510	0x8510	0x8510	0x8510	0x8510	0x8510
	DMA with 3 channels	0x1A76	2	0x4704	0x4704	0x4704	0x4704	0x4704	0x4704
	USCI_A0/B0	0x1A78	2	0x900C	0x900C	0x900C	0x900C	0x900C	0x900C
	COMP_B	0x1A7A	2	0xA830	0xA830	0xA830	0xA830	0xA830	0xA830
	TIMER_D0	0x1A7C	2	0xD624	0xD624	0xD624	0xD624	0xD624	0xD624
	TIMER_D1	0x1A7E	2	0x6D04	0x6D04	0x6D04	0x6D04	0x6D04	0x6D04
	TEC_0	0x1A80	2	0x700C	0x700C	0x700C	0x700C	0x700C	0x700C
	TEC_1	0x1A82	2	0x7002	0x7002	0x7002	0x7002	0x7002	0x7002
<b>Interrupts</b>	COMP_B	0x1A83	1	0xA8	0xA8	0xA8	0xA8	0xA8	0xA8
	TEC_0	0x1A84	1	0x6D	0x6D	0x6D	0x6D	0x6D	0x6D

**Table 59. 'F51x1 Device Descriptor Table<sup>(1)</sup> (continued)**

	Description	Address	Size bytes	'F5171 RSB	'F5171 DA	'F5151 RSB	'F5151 DA	'F5131 RSB	'F5131 DA
				Value	Value	Value	Value	Value	Value
	TIMER_D0	0x1A85	1	0x62	0x62	0x62	0x62	0x62	0x62
	TIMER_D0	0x1A86	1	0x63	0x63	0x63	0x63	0x63	0x63
	WDTIFG	0x1A87	1	0x40	0x40	0x40	0x40	0x40	0x40
	USCI_A0	0x1A88	1	0x90	0x90	0x90	0x90	0x90	0x90
	USCI_B0	0x1A89	1	0x91	0x91	0x91	0x91	0x91	0x91
	ADC10_A	0x1A8A	1	0xD0	0xD0	0xD0	0xD0	0xD0	0xD0
	TA0.CCIFG0	0x1A8B	1	0x60	0x60	0x60	0x60	0x60	0x60
	TA0.CCIFG1..4	0x1A8C	1	0x61	0x61	0x61	0x61	0x61	0x61
	DMA	0x1A8D	1	0x46	0x46	0x46	0x46	0x46	0x46
	TEC_1	0x1A8E	1	0x6E	0x6E	0x6E	0x6E	0x6E	0x6E
	TIMER_D1	0x1A8F	1	0x64	0x64	0x64	0x64	0x64	0x64
	TIMER_D1	0x1A90	1	0x65	0x65	0x65	0x65	0x65	0x65
	Port P1	0x1A91	1	0x50	0x50	0x50	0x50	0x50	0x50
	Port P2	0x1A92	1	0x51	0x51	0x51	0x51	0x51	0x51
	delimiter	0x1A93	1	0x00	0x00	0x00	0x00	0x00	0x00
<b>Empty</b>	Unused Memory	0x1A94 - 0x1AB9		0xFF	0xFF	0xFF	0xFF	0xFF	0xFF

## REVISION HISTORY

REVISION	COMMENTS
SLAS619	Product Preview release
SLAS619A	Production Data release
SLAS619B	Changed <a href="#">Table 7</a> .
SLAS619C	Changed Comparator_B $V_{REF}$ MAX from $\pm 1\%$ to $\pm 1.5\%$ for all test conditions in <a href="#">Comparator_B</a> .
SLAS619D	<p><a href="#">Table 1</a>, Corrected number of I/Os for all entries.</p> <p><a href="#">Functional Block Diagram, MSP430F51x2</a> and <a href="#">Functional Block Diagram, MSP430F51x1</a>, Corrected typo on P2 port name.</p> <p><a href="#">Recommended Operating Conditions</a>, Corrected typo in <math>f_{SYSTEM}</math> <math>V_{CC}</math> conditions on <math>V_{CORE} = 3</math> row.</p> <p><a href="#">PMM, Brown-Out Reset (BOR)</a>, Changed parameter descriptions for <math>V_{(DVCC\_BOR\_IT-)}</math> and <math>V_{(VCORE\_BOR\_IT-)}</math>.</p>

**PACKAGING INFORMATION**

Orderable Device	Status <sup>(1)</sup>	Package Type	Package Drawing	Pins	Package Qty	Eco Plan <sup>(2)</sup>	Lead/ Ball Finish	MSL Peak Temp <sup>(3)</sup>	Samples (Requires Login)
MSP430F5131IDA	ACTIVE	TSSOP	DA	38	40	Green (RoHS & no Sb/Br)	CU NIPDAU	Level-2-260C-1 YEAR	
MSP430F5131IDAR	ACTIVE	TSSOP	DA	38	2000	Green (RoHS & no Sb/Br)	CU NIPDAU	Level-2-260C-1 YEAR	
MSP430F5131IRSBR	ACTIVE	WQFN	RSB	40	3000	Green (RoHS & no Sb/Br)	CU NIPDAU	Level-2-260C-1 YEAR	
MSP430F5131IRSBT	ACTIVE	WQFN	RSB	40	250	Green (RoHS & no Sb/Br)	CU NIPDAU	Level-2-260C-1 YEAR	
MSP430F5132IDA	ACTIVE	TSSOP	DA	38	40	Green (RoHS & no Sb/Br)	CU NIPDAU	Level-2-260C-1 YEAR	
MSP430F5132IDAR	ACTIVE	TSSOP	DA	38	2000	Green (RoHS & no Sb/Br)	CU NIPDAU	Level-2-260C-1 YEAR	
MSP430F5132IRHAR	OBSOLETE	VQFN	RHA	40		TBD	Call TI	Call TI	
MSP430F5132IRHAT	OBSOLETE	VQFN	RHA	40		TBD	Call TI	Call TI	
MSP430F5132IRSBR	ACTIVE	WQFN	RSB	40	3000	Green (RoHS & no Sb/Br)	CU NIPDAU	Level-2-260C-1 YEAR	
MSP430F5132IRSBT	ACTIVE	WQFN	RSB	40	250	Green (RoHS & no Sb/Br)	CU NIPDAU	Level-2-260C-1 YEAR	
MSP430F5151IDA	ACTIVE	TSSOP	DA	38	40	Green (RoHS & no Sb/Br)	CU NIPDAU	Level-2-260C-1 YEAR	
MSP430F5151IDAR	ACTIVE	TSSOP	DA	38	2000	Green (RoHS & no Sb/Br)	CU NIPDAU	Level-2-260C-1 YEAR	
MSP430F5151IRSBR	ACTIVE	WQFN	RSB	40	3000	Green (RoHS & no Sb/Br)	CU NIPDAU	Level-2-260C-1 YEAR	
MSP430F5151IRSBT	ACTIVE	WQFN	RSB	40	250	Green (RoHS & no Sb/Br)	CU NIPDAU	Level-2-260C-1 YEAR	
MSP430F5152IDA	ACTIVE	TSSOP	DA	38	40	Green (RoHS & no Sb/Br)	CU NIPDAU	Level-2-260C-1 YEAR	
MSP430F5152IDAR	ACTIVE	TSSOP	DA	38	2000	Green (RoHS & no Sb/Br)	CU NIPDAU	Level-2-260C-1 YEAR	
MSP430F5152IRHAR	OBSOLETE	VQFN	RHA	40		TBD	Call TI	Call TI	
MSP430F5152IRHAT	OBSOLETE	VQFN	RHA	40		TBD	Call TI	Call TI	

Orderable Device	Status <sup>(1)</sup>	Package Type	Package Drawing	Pins	Package Qty	Eco Plan <sup>(2)</sup>	Lead/ Ball Finish	MSL Peak Temp <sup>(3)</sup>	Samples (Requires Login)
MSP430F5152IRSBR	ACTIVE	WQFN	RSB	40	3000	Green (RoHS & no Sb/Br)	CU NIPDAU	Level-2-260C-1 YEAR	
MSP430F5152IRSBT	ACTIVE	WQFN	RSB	40	250	Green (RoHS & no Sb/Br)	CU NIPDAU	Level-2-260C-1 YEAR	
MSP430F5171IDA	ACTIVE	TSSOP	DA	38	40	Green (RoHS & no Sb/Br)	CU NIPDAU	Level-2-260C-1 YEAR	
MSP430F5171IDAR	ACTIVE	TSSOP	DA	38	2000	Green (RoHS & no Sb/Br)	CU NIPDAU	Level-2-260C-1 YEAR	
MSP430F5171IRSBR	ACTIVE	WQFN	RSB	40	3000	Green (RoHS & no Sb/Br)	CU NIPDAU	Level-2-260C-1 YEAR	
MSP430F5171IRSBT	ACTIVE	WQFN	RSB	40	250	Green (RoHS & no Sb/Br)	CU NIPDAU	Level-2-260C-1 YEAR	
MSP430F5172CY	PREVIEW	DIESALE	Y	0	550	Green (RoHS & no Sb/Br)	Call TI	N / A for Pkg Type	
MSP430F5172CYS	PREVIEW	WAFERSALE	YS	0	1	TBD	Call TI	Call TI	
MSP430F5172IDA	ACTIVE	TSSOP	DA	38	40	Green (RoHS & no Sb/Br)	CU NIPDAU	Level-2-260C-1 YEAR	
MSP430F5172IDAR	ACTIVE	TSSOP	DA	38	2000	Green (RoHS & no Sb/Br)	CU NIPDAU	Level-2-260C-1 YEAR	
MSP430F5172IRHAR	OBSOLETE	VQFN	RHA	40		TBD	Call TI	Call TI	
MSP430F5172IRHAT	OBSOLETE	VQFN	RHA	40		TBD	Call TI	Call TI	
MSP430F5172IRSB	OBSOLETE	WQFN	RSB	40		TBD	Call TI	Call TI	
MSP430F5172IRSBR	ACTIVE	WQFN	RSB	40	3000	Green (RoHS & no Sb/Br)	CU NIPDAU	Level-2-260C-1 YEAR	
MSP430F5172IRSBT	ACTIVE	WQFN	RSB	40	250	Green (RoHS & no Sb/Br)	CU NIPDAU	Level-2-260C-1 YEAR	
XMS430F5172IDAR	OBSOLETE	TSSOP	DA	38		TBD	Call TI	Call TI	
XMS430F5172IRSBR	OBSOLETE	WQFN	RSB	40		TBD	Call TI	Call TI	

<sup>(1)</sup> The marketing status values are defined as follows:

**ACTIVE:** Product device recommended for new designs.

**LIFEBUY:** TI has announced that the device will be discontinued, and a lifetime-buy period is in effect.

**NRND:** Not recommended for new designs. Device is in production to support existing customers, but TI does not recommend using this part in a new design.

**PREVIEW:** Device has been announced but is not in production. Samples may or may not be available.

**OBSOLETE:** TI has discontinued the production of the device.

---

<sup>(2)</sup> Eco Plan - The planned eco-friendly classification: Pb-Free (RoHS), Pb-Free (RoHS Exempt), or Green (RoHS & no Sb/Br) - please check <http://www.ti.com/productcontent> for the latest availability information and additional product content details.

**TBD:** The Pb-Free/Green conversion plan has not been defined.

**Pb-Free (RoHS):** TI's terms "Lead-Free" or "Pb-Free" mean semiconductor products that are compatible with the current RoHS requirements for all 6 substances, including the requirement that lead not exceed 0.1% by weight in homogeneous materials. Where designed to be soldered at high temperatures, TI Pb-Free products are suitable for use in specified lead-free processes.

**Pb-Free (RoHS Exempt):** This component has a RoHS exemption for either 1) lead-based flip-chip solder bumps used between the die and package, or 2) lead-based die adhesive used between the die and leadframe. The component is otherwise considered Pb-Free (RoHS compatible) as defined above.

**Green (RoHS & no Sb/Br):** TI defines "Green" to mean Pb-Free (RoHS compatible), and free of Bromine (Br) and Antimony (Sb) based flame retardants (Br or Sb do not exceed 0.1% by weight in homogeneous material)

<sup>(3)</sup> MSL, Peak Temp. -- The Moisture Sensitivity Level rating according to the JEDEC industry standard classifications, and peak solder temperature.

**Important Information and Disclaimer:** The information provided on this page represents TI's knowledge and belief as of the date that it is provided. TI bases its knowledge and belief on information provided by third parties, and makes no representation or warranty as to the accuracy of such information. Efforts are underway to better integrate information from third parties. TI has taken and continues to take reasonable steps to provide representative and accurate information but may not have conducted destructive testing or chemical analysis on incoming materials and chemicals. TI and TI suppliers consider certain information to be proprietary, and thus CAS numbers and other limited information may not be available for release.

In no event shall TI's liability arising out of such information exceed the total purchase price of the TI part(s) at issue in this document sold by TI to Customer on an annual basis.

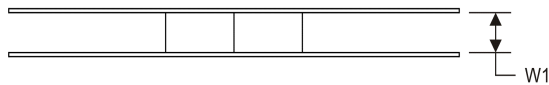
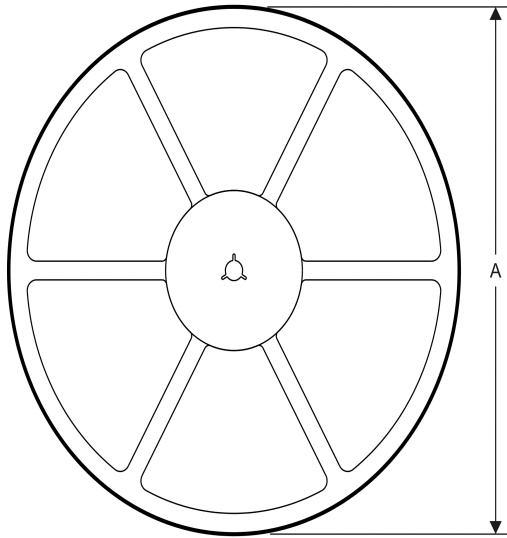
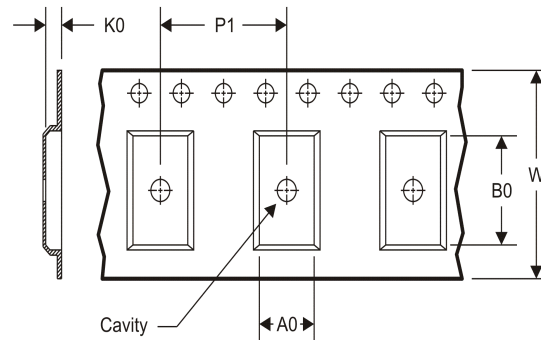
**TAPE AND REEL INFORMATION**
**REEL DIMENSIONS**

**TAPE DIMENSIONS**

A0	Dimension designed to accommodate the component width
B0	Dimension designed to accommodate the component length
K0	Dimension designed to accommodate the component thickness
W	Overall width of the carrier tape
P1	Pitch between successive cavity centers

**TAPE AND REEL INFORMATION**

\*All dimensions are nominal

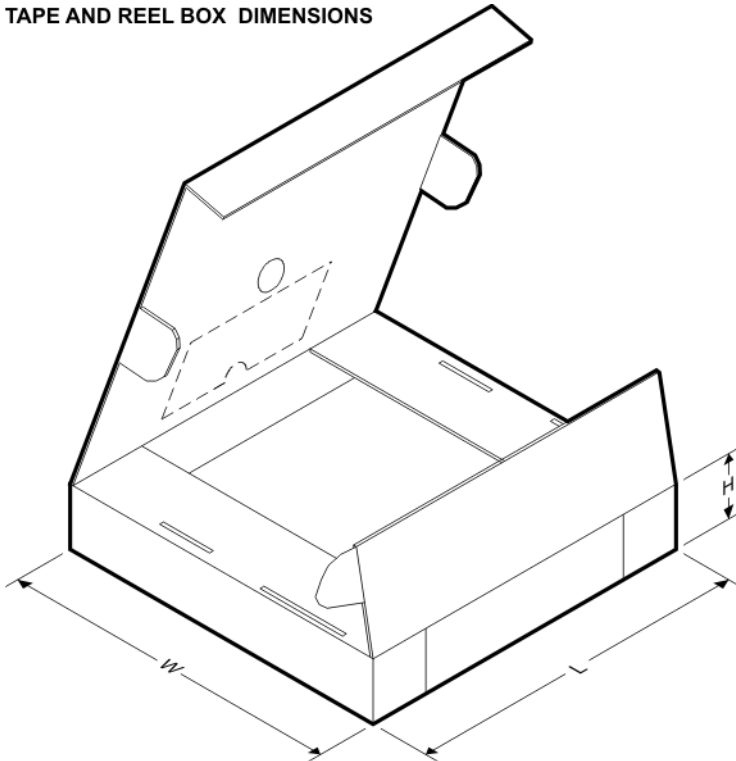
Device	Package Type	Package Drawing	Pins	SPQ	Reel Diameter (mm)	Reel Width W1 (mm)	A0 (mm)	B0 (mm)	K0 (mm)	P1 (mm)	W (mm)	Pin1 Quadrant
MSP430F5131IDAR	TSSOP	DA	38	2000	330.0	24.4	8.6	13.0	1.8	12.0	24.0	Q1
MSP430F5131IRSBR	WQFN	RSB	40	3000	330.0	12.4	5.3	5.3	1.5	8.0	12.0	Q2
MSP430F5131IRSBT	WQFN	RSB	40	250	180.0	12.4	5.3	5.3	1.5	8.0	12.0	Q2
MSP430F5132IDAR	TSSOP	DA	38	2000	330.0	24.4	8.6	13.0	1.8	12.0	24.0	Q1
MSP430F5132IRSBR	WQFN	RSB	40	3000	330.0	12.4	5.3	5.3	1.5	8.0	12.0	Q2
MSP430F5132IRSBT	WQFN	RSB	40	250	180.0	12.4	5.3	5.3	1.5	8.0	12.0	Q2
MSP430F5151IDAR	TSSOP	DA	38	2000	330.0	24.4	8.6	13.0	1.8	12.0	24.0	Q1
MSP430F5151IRSBR	WQFN	RSB	40	3000	330.0	12.4	5.3	5.3	1.5	8.0	12.0	Q2
MSP430F5151IRSBT	WQFN	RSB	40	250	180.0	12.4	5.3	5.3	1.5	8.0	12.0	Q2
MSP430F5152IDAR	TSSOP	DA	38	2000	330.0	24.4	8.6	13.0	1.8	12.0	24.0	Q1
MSP430F5152IRSBR	WQFN	RSB	40	3000	330.0	12.4	5.3	5.3	1.5	8.0	12.0	Q2
MSP430F5152IRSBT	WQFN	RSB	40	250	180.0	12.4	5.3	5.3	1.5	8.0	12.0	Q2
MSP430F5171IDAR	TSSOP	DA	38	2000	330.0	24.4	8.6	13.0	1.8	12.0	24.0	Q1
MSP430F5171IRSBR	WQFN	RSB	40	3000	330.0	12.4	5.3	5.3	1.5	8.0	12.0	Q2
MSP430F5171IRSBT	WQFN	RSB	40	250	180.0	12.4	5.3	5.3	1.5	8.0	12.0	Q2
MSP430F5172IDAR	TSSOP	DA	38	2000	330.0	24.4	8.6	13.0	1.8	12.0	24.0	Q1
MSP430F5172IRSBR	WQFN	RSB	40	3000	330.0	12.4	5.3	5.3	1.5	8.0	12.0	Q2

**TAPE AND REEL BOX DIMENSIONS**

\*All dimensions are nominal

Device	Package Type	Package Drawing	Pins	SPQ	Length (mm)	Width (mm)	Height (mm)
MSP430F5131IDAR	TSSOP	DA	38	2000	346.0	346.0	41.0
MSP430F5131IRSB	WQFN	RSB	40	3000	346.0	346.0	29.0
MSP430F5131IRSBT	WQFN	RSB	40	250	210.0	185.0	35.0
MSP430F5132IDAR	TSSOP	DA	38	2000	346.0	346.0	41.0
MSP430F5132IRSB	WQFN	RSB	40	3000	346.0	346.0	29.0
MSP430F5132IRSBT	WQFN	RSB	40	250	210.0	185.0	35.0
MSP430F5151IDAR	TSSOP	DA	38	2000	346.0	346.0	41.0
MSP430F5151IRSB	WQFN	RSB	40	3000	346.0	346.0	29.0
MSP430F5151IRSBT	WQFN	RSB	40	250	210.0	185.0	35.0
MSP430F5152IDAR	TSSOP	DA	38	2000	346.0	346.0	41.0
MSP430F5152IRSB	WQFN	RSB	40	3000	346.0	346.0	29.0
MSP430F5152IRSBT	WQFN	RSB	40	250	210.0	185.0	35.0
MSP430F5171IDAR	TSSOP	DA	38	2000	346.0	346.0	41.0
MSP430F5171IRSB	WQFN	RSB	40	3000	346.0	346.0	29.0
MSP430F5171IRSBT	WQFN	RSB	40	250	210.0	185.0	35.0
MSP430F5172IDAR	TSSOP	DA	38	2000	346.0	346.0	41.0
MSP430F5172IRSB	WQFN	RSB	40	3000	346.0	346.0	29.0

RHA (S-PVQFN-N40)

PLASTIC QUAD FLATPACK NO-LEAD

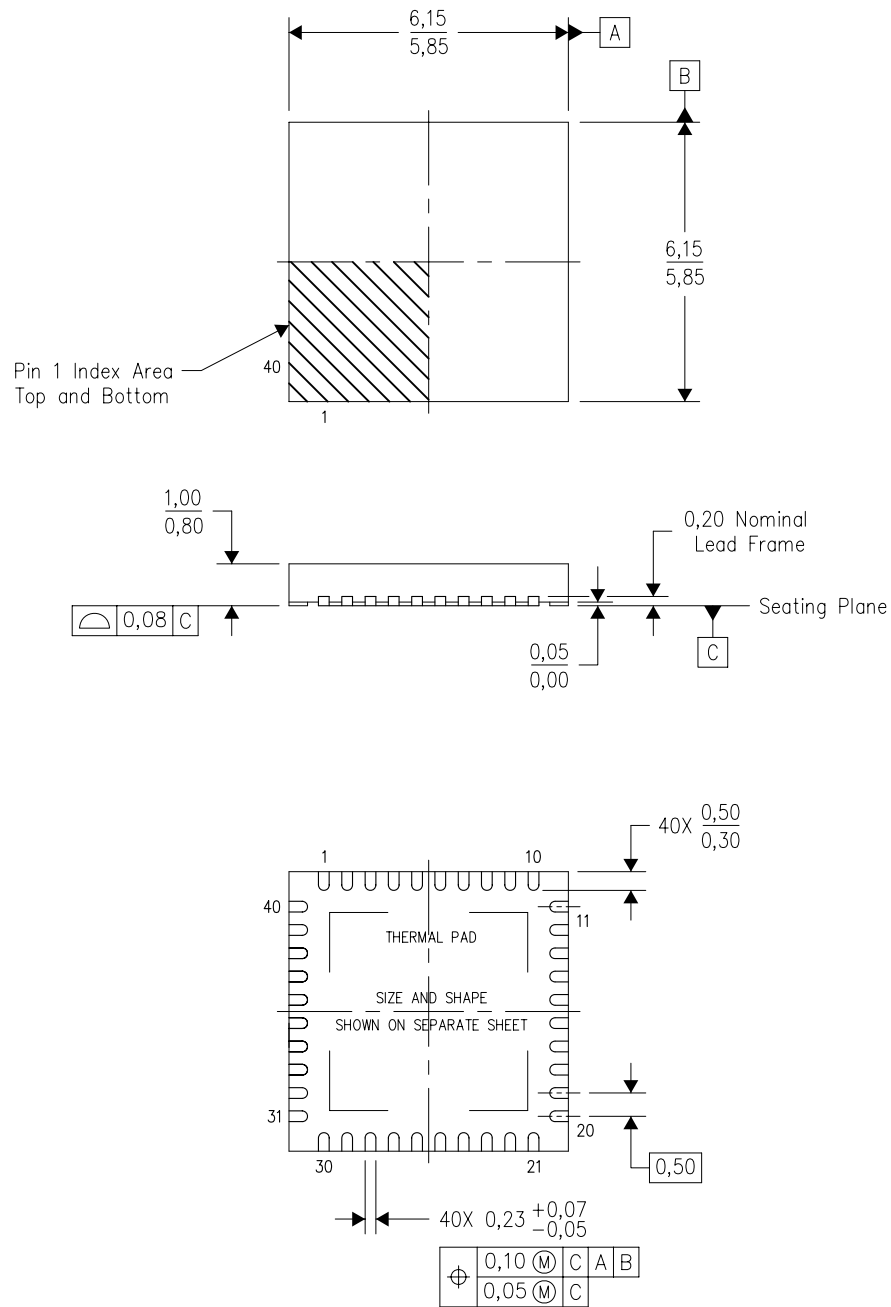

Bottom View

4204276/E 06/11

- NOTES:
- All linear dimensions are in millimeters. Dimensioning and tolerancing per ASME Y14.5M-1994.
  - This drawing is subject to change without notice.
  - QFN (Quad Flatpack No-Lead) Package configuration.
  - The package thermal pad must be soldered to the board for thermal and mechanical performance.
  - See the additional figure in the Product Data Sheet for details regarding the exposed thermal pad features and dimensions.
  - Package complies to JEDEC MO-220 variation VJJD-2.

RSB (S-PWQFN-N40)

PLASTIC QUAD FLATPACK NO-LEAD

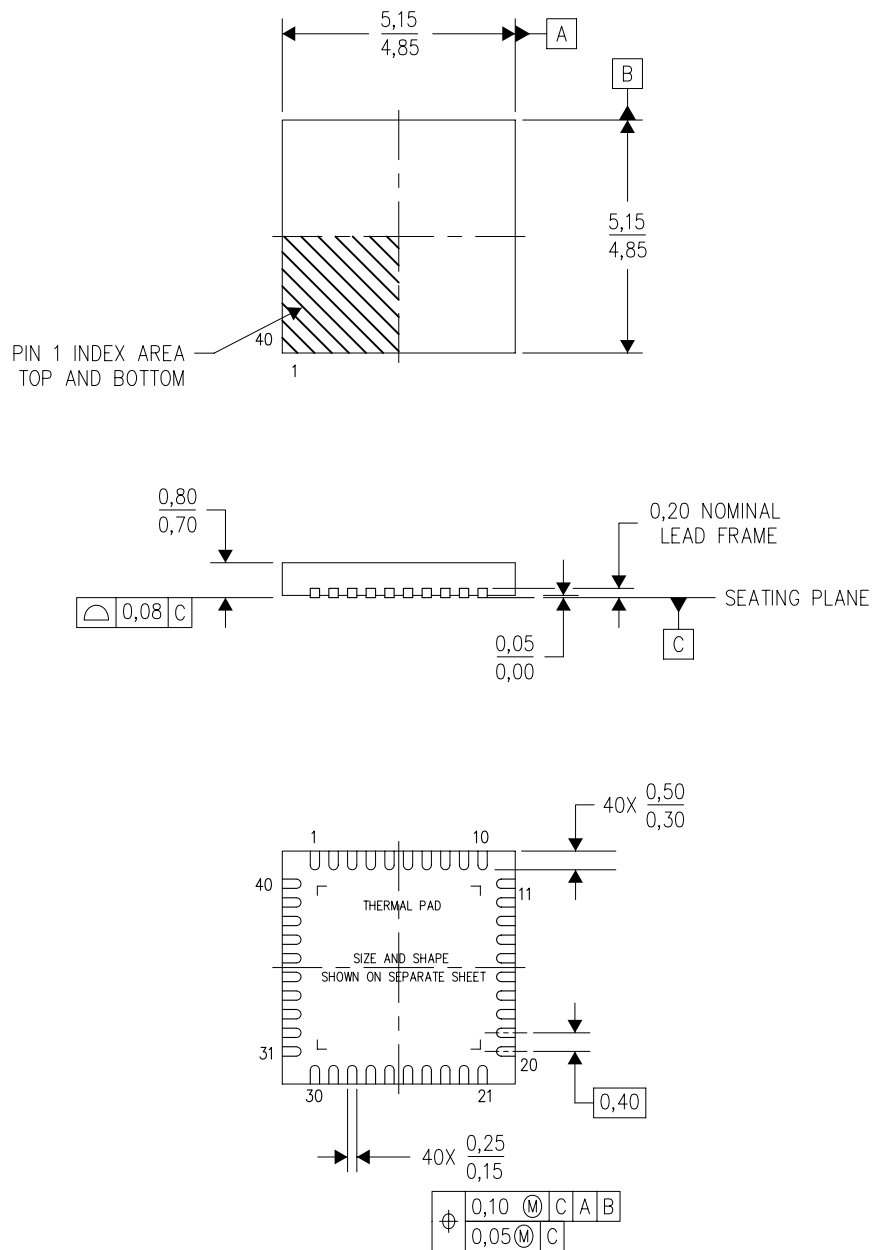

4207182/C 05/11

- NOTES:
- All linear dimensions are in millimeters. Dimensioning and tolerancing per ASME Y14.5M-1994.
  - This drawing is subject to change without notice.
  - QFN (Quad Flatpack No-Lead) Package configuration.
  - The package thermal pad must be soldered to the board for thermal and mechanical performance.
  - See the additional figure in the Product Data Sheet for details regarding the exposed thermal pad features and dimensions.

## THERMAL PAD MECHANICAL DATA

RSB (S-PWQFN-N40)

PLASTIC QUAD FLATPACK NO-LEAD

### THERMAL INFORMATION

This package incorporates an exposed thermal pad that is designed to be attached directly to an external heatsink. The thermal pad must be soldered directly to the printed circuit board (PCB). After soldering, the PCB can be used as a heatsink. In addition, through the use of thermal vias, the thermal pad can be attached directly to the appropriate copper plane shown in the electrical schematic for the device, or alternatively, can be attached to a special heatsink structure designed into the PCB. This design optimizes the heat transfer from the integrated circuit (IC).

For information on the Quad Flatpack No-Lead (QFN) package and its advantages, refer to Application Report, QFN/SON PCB Attachment, Texas Instruments Literature No. SLUA271. This document is available at [www.ti.com](http://www.ti.com).

The exposed thermal pad dimensions for this package are shown in the following illustration.

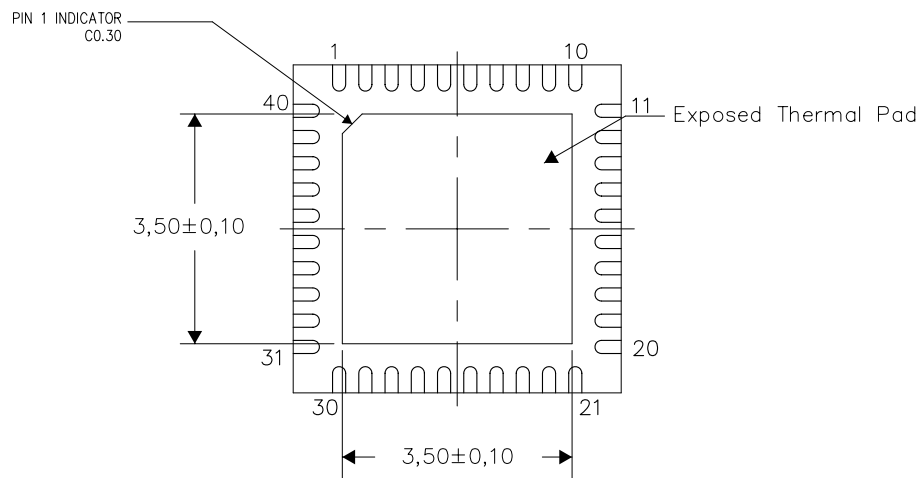

Bottom View

Exposed Thermal Pad Dimensions

4207183-2/L 01/12

NOTE: All linear dimensions are in millimeters

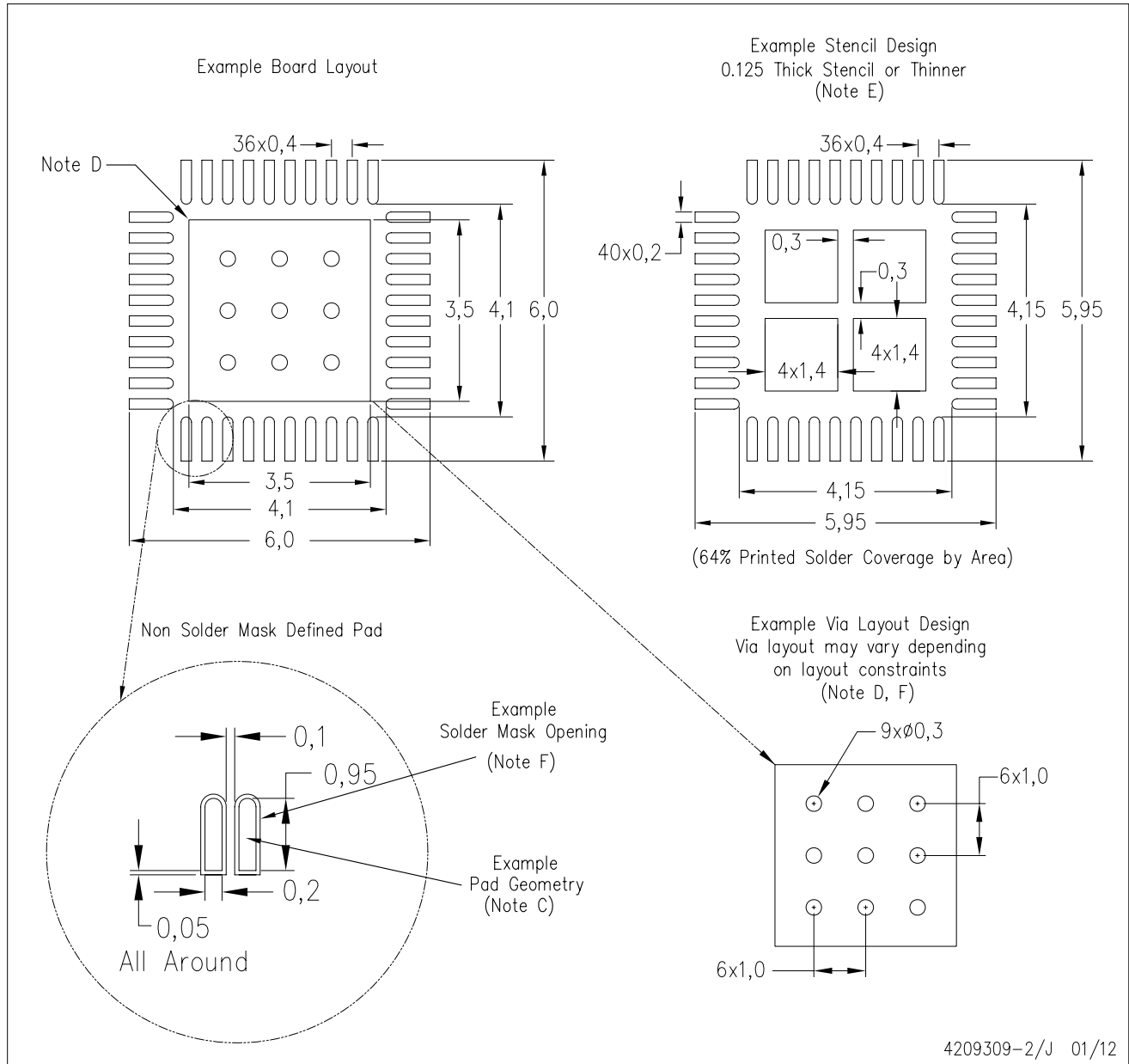

- NOTES:
- A. All linear dimensions are in millimeters.
  - B. This drawing is subject to change without notice.
  - C. Publication IPC-7351 is recommended for alternate designs.
  - D. This package is designed to be soldered to a thermal pad on the board. Refer to Application Note, Quad Flat-Pack Packages, Texas Instruments Literature No. SLUA271, and also the Product Data Sheets for specific thermal information, via requirements, and recommended board layout. These documents are available at [www.ti.com](http://www.ti.com) <<http://www.ti.com>>.
  - E. Laser cutting apertures with trapezoidal walls and also rounding corners will offer better paste release. Customers should contact their board assembly site for stencil design recommendations. Refer to IPC 7525 for stencil design considerations.
  - F. Customers should contact their board fabrication site for recommended solder mask tolerances and via tenting recommendations for vias placed in the thermal pad.

DA (R-PDSO-G\*\*)   
 38 PIN SHOWN

PLASTIC SMALL-OUTLINE PACKAGE

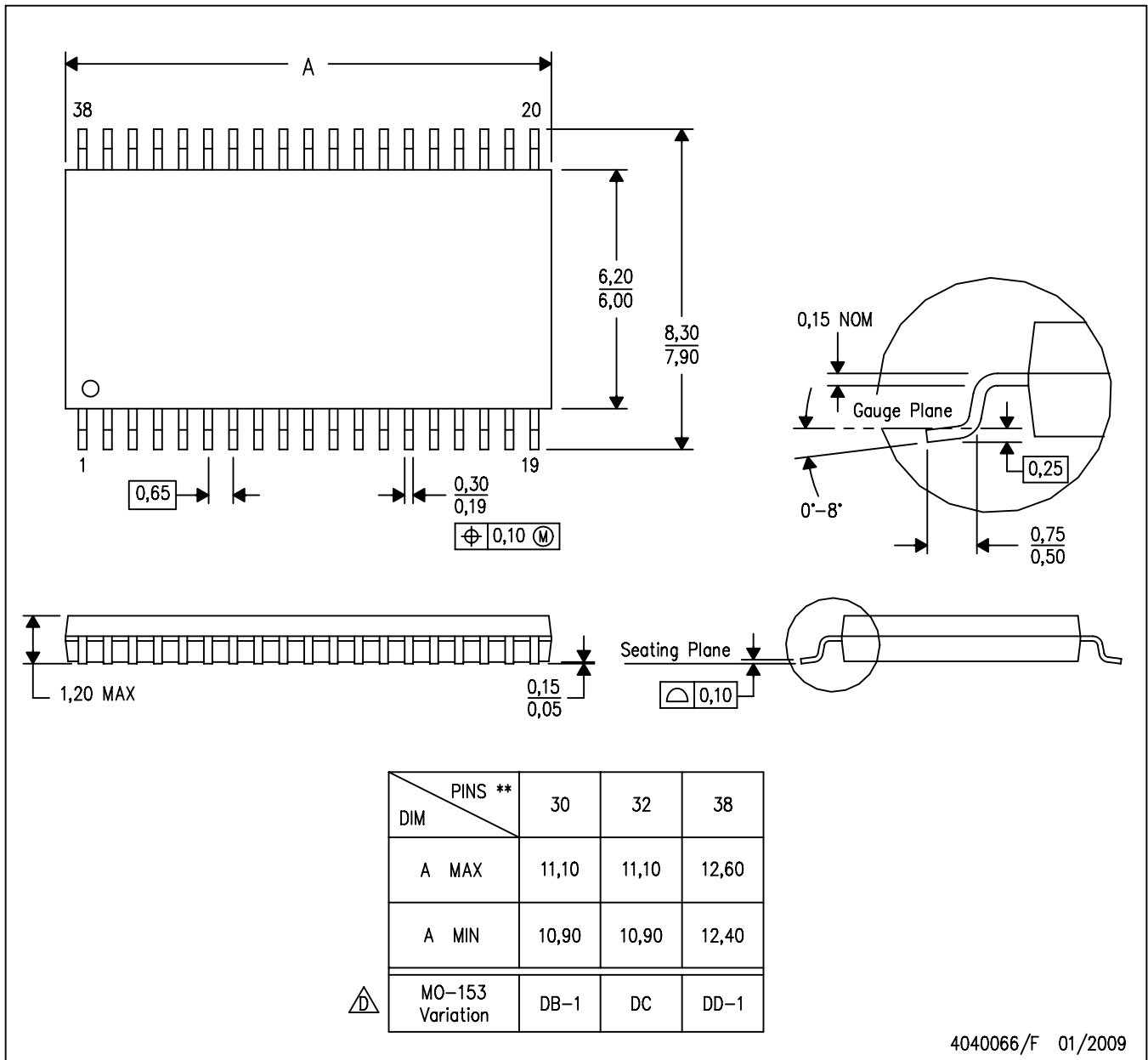

- NOTES:
- A. All linear dimensions are in millimeters.
  - B. This drawing is subject to change without notice.
  - C. Body dimensions do not include mold flash or protrusion. Mold flash and protrusion shall not exceed 0.15 per side.
  - Falls within JEDEC MO-153, except 30 pin body length.

DA (R-PDSO-G38)

PLASTIC SMALL OUTLINE

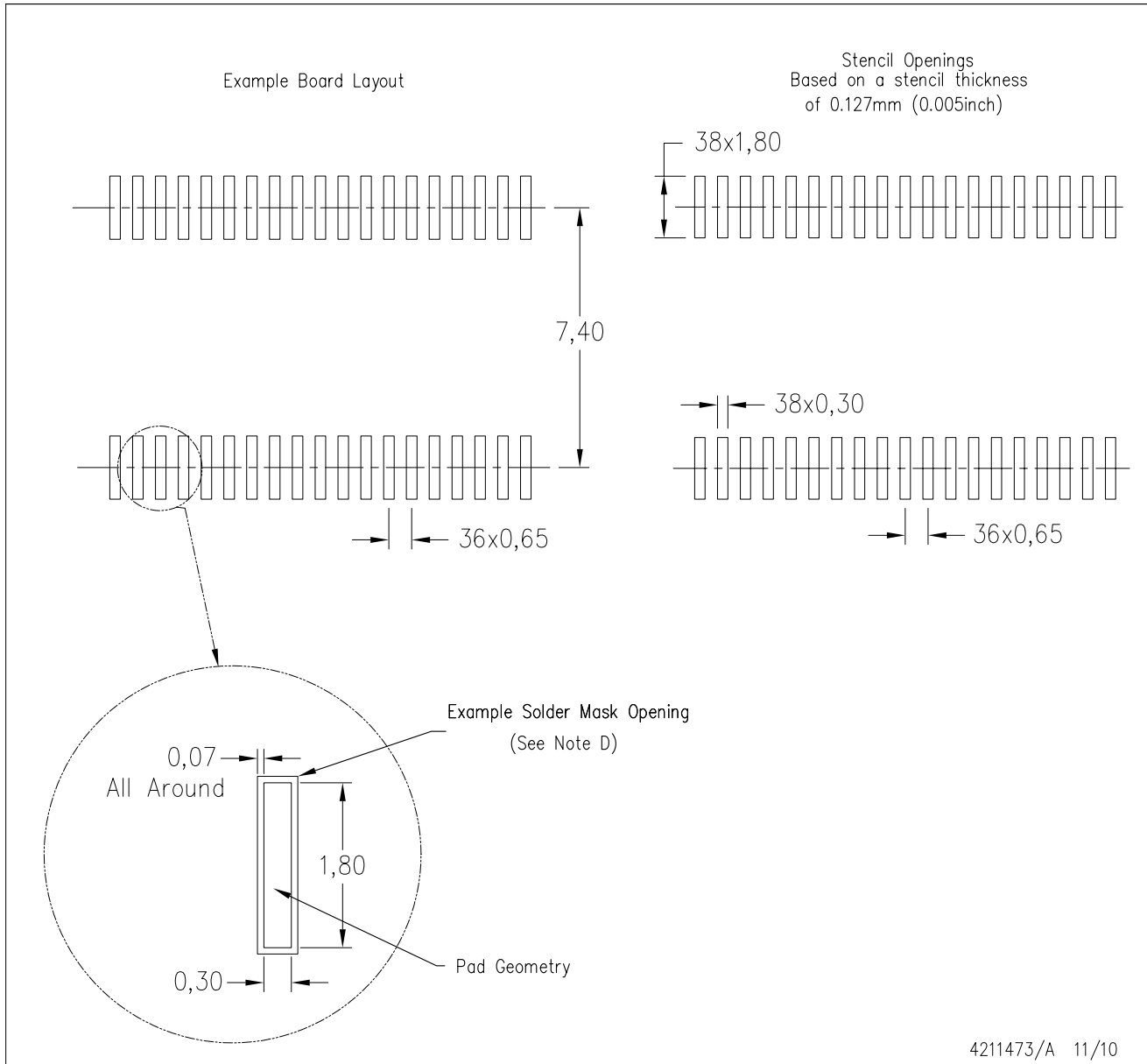

- NOTES:
- A. All linear dimensions are in millimeters.
  - B. This drawing is subject to change without notice.
  - C. Laser cutting apertures with trapezoidal walls and also rounding corners will offer better paste release. Customers should contact their board assembly site for stencil design recommendations. Example stencil design based on a 50% volumetric metal load solder paste. Refer to IPC-7525 for other stencil recommendations.
  - D. Contact the board fabrication site for recommended soldermask tolerances.

## IMPORTANT NOTICE

Texas Instruments Incorporated and its subsidiaries (TI) reserve the right to make corrections, modifications, enhancements, improvements, and other changes to its products and services at any time and to discontinue any product or service without notice. Customers should obtain the latest relevant information before placing orders and should verify that such information is current and complete. All products are sold subject to TI's terms and conditions of sale supplied at the time of order acknowledgment.

TI warrants performance of its hardware products to the specifications applicable at the time of sale in accordance with TI's standard warranty. Testing and other quality control techniques are used to the extent TI deems necessary to support this warranty. Except where mandated by government requirements, testing of all parameters of each product is not necessarily performed.

TI assumes no liability for applications assistance or customer product design. Customers are responsible for their products and applications using TI components. To minimize the risks associated with customer products and applications, customers should provide adequate design and operating safeguards.

TI does not warrant or represent that any license, either express or implied, is granted under any TI patent right, copyright, mask work right, or other TI intellectual property right relating to any combination, machine, or process in which TI products or services are used. Information published by TI regarding third-party products or services does not constitute a license from TI to use such products or services or a warranty or endorsement thereof. Use of such information may require a license from a third party under the patents or other intellectual property of the third party, or a license from TI under the patents or other intellectual property of TI.

Reproduction of TI information in TI data books or data sheets is permissible only if reproduction is without alteration and is accompanied by all associated warranties, conditions, limitations, and notices. Reproduction of this information with alteration is an unfair and deceptive business practice. TI is not responsible or liable for such altered documentation. Information of third parties may be subject to additional restrictions.

Resale of TI products or services with statements different from or beyond the parameters stated by TI for that product or service voids all express and any implied warranties for the associated TI product or service and is an unfair and deceptive business practice. TI is not responsible or liable for any such statements.

TI products are not authorized for use in safety-critical applications (such as life support) where a failure of the TI product would reasonably be expected to cause severe personal injury or death, unless officers of the parties have executed an agreement specifically governing such use. Buyers represent that they have all necessary expertise in the safety and regulatory ramifications of their applications, and acknowledge and agree that they are solely responsible for all legal, regulatory and safety-related requirements concerning their products and any use of TI products in such safety-critical applications, notwithstanding any applications-related information or support that may be provided by TI. Further, Buyers must fully indemnify TI and its representatives against any damages arising out of the use of TI products in such safety-critical applications.

TI products are neither designed nor intended for use in military/aerospace applications or environments unless the TI products are specifically designated by TI as military-grade or "enhanced plastic." Only products designated by TI as military-grade meet military specifications. Buyers acknowledge and agree that any such use of TI products which TI has not designated as military-grade is solely at the Buyer's risk, and that they are solely responsible for compliance with all legal and regulatory requirements in connection with such use.

TI products are neither designed nor intended for use in automotive applications or environments unless the specific TI products are designated by TI as compliant with ISO/TS 16949 requirements. Buyers acknowledge and agree that, if they use any non-designated products in automotive applications, TI will not be responsible for any failure to meet such requirements.

Following are URLs where you can obtain information on other Texas Instruments products and application solutions:

### Products

Audio	<a href="http://www.ti.com/audio">www.ti.com/audio</a>
Amplifiers	<a href="http://amplifier.ti.com">amplifier.ti.com</a>
Data Converters	<a href="http://dataconverter.ti.com">dataconverter.ti.com</a>
DLP® Products	<a href="http://www.dlp.com">www.dlp.com</a>
DSP	<a href="http://dsp.ti.com">dsp.ti.com</a>
Clocks and Timers	<a href="http://www.ti.com/clocks">www.ti.com/clocks</a>
Interface	<a href="http://interface.ti.com">interface.ti.com</a>
Logic	<a href="http://logic.ti.com">logic.ti.com</a>
Power Mgmt	<a href="http://power.ti.com">power.ti.com</a>
Microcontrollers	<a href="http://microcontroller.ti.com">microcontroller.ti.com</a>
RFID	<a href="http://www.ti-rfid.com">www.ti-rfid.com</a>
OMAP Mobile Processors	<a href="http://www.ti.com/omap">www.ti.com/omap</a>
Wireless Connectivity	<a href="http://www.ti.com/wirelessconnectivity">www.ti.com/wirelessconnectivity</a>

### Applications

Automotive and Transportation	<a href="http://www.ti.com/automotive">www.ti.com/automotive</a>
Communications and Telecom	<a href="http://www.ti.com/communications">www.ti.com/communications</a>
Computers and Peripherals	<a href="http://www.ti.com/computers">www.ti.com/computers</a>
Consumer Electronics	<a href="http://www.ti.com/consumer-apps">www.ti.com/consumer-apps</a>
Energy and Lighting	<a href="http://www.ti.com/energy">www.ti.com/energy</a>
Industrial	<a href="http://www.ti.com/industrial">www.ti.com/industrial</a>
Medical	<a href="http://www.ti.com/medical">www.ti.com/medical</a>
Security	<a href="http://www.ti.com/security">www.ti.com/security</a>
Space, Avionics and Defense	<a href="http://www.ti.com/space-avionics-defense">www.ti.com/space-avionics-defense</a>
Video and Imaging	<a href="http://www.ti.com/video">www.ti.com/video</a>

TI E2E Community Home Page

[e2e.ti.com](http://e2e.ti.com)

Mailing Address: Texas Instruments, Post Office Box 655303, Dallas, Texas 75265  
Copyright © 2012, Texas Instruments Incorporated